

## LINEAR INTEGRATED CIRCUITS

### DESCRIPTION

The SE/NE 567 tone and frequency decoder is a highly stable phase-locked loop with synchronous AM lock detection and power output circuitry. Its primary function is to drive a load whenever a sustained frequency within its detection band is present at the self-biased input. The bandwidth center frequency, and output delay are independently determined by means of four external components.

### FEATURES

- WIDE FREQUENCY RANGE (.01Hz to 500kHz)
- HIGH STABILITY OF CENTER FREQUENCY
- INDEPENDENTLY CONTROLLABLE BANDWIDTH (0 TO 14 PERCENT)
- HIGH OUT-BAND SIGNAL AND NOISE REJECTION
- LOGIC-COMPATIBLE OUTPUT WITH 100mA CURRENT SINKING CAPABILITY
- INHERENT IMMUNITY TO FALSE SIGNALS
- FREQUENCY ADJUSTMENT OVER A 20 TO 1 RANGE WITH AN EXTERNAL RESISTOR

### APPLICATIONS

- TOUCH TONE<sup>®</sup> DECODING
- CARRIER CURRENT REMOTE CONTROLS
- ULTRASONIC CONTROLS (REMOTE TV, ETC.)
- COMMUNICATIONS PAGING
- FREQUENCY MONITORING AND CONTROL
- WIRELESS INTERCOM
- PRECISION OSCILLATOR

### BLOCK DIAGRAM

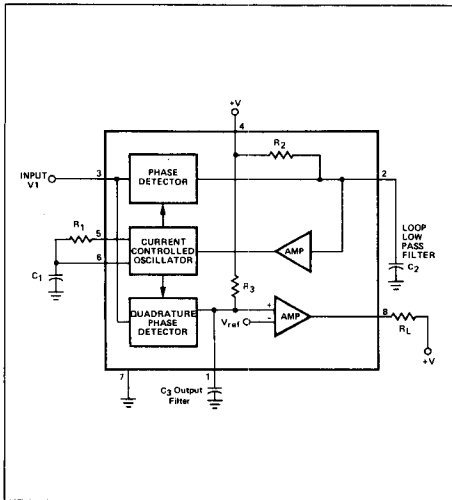

### PIN CONFIGURATION

#### T PACKAGE (Top View)

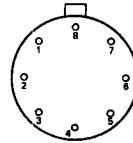

1. Output Filter Capacitor  $C_3$
2. Low Pass Filter Capacitor  $C_2$
3. Input
4. Supply Voltage +V
5. Timing Element  $R_1$
6. Timing Elements  $R_1$  and  $C_1$
7. Ground
8. Output

ORDER PART NOS. SE567T/NE567T

#### V PACKAGE

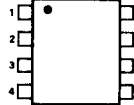

1. Output Filter Capacitor  $C_3$
2. Low Pass Filter Capacitor  $C_2$
3. Input
4. Supply Voltage +V
5. Timing Element  $R_1$
6. Timing Elements  $R_1$  and  $C_1$
7. Ground
8. Output

ORDER PART NO. NE567V

### ABSOLUTE MAXIMUM RATINGS:

Operating Temperature	0°C to 70°C NE567 -55°C to 125°C SE567
Operating Voltage	10V
Positive Voltage at Input	0.5V above Supply Voltage (Pin 4)
Negative Voltage at Input	-10 VDC
Output Voltage (collector of output transistor)	15 VDC
Storage Temperature	-65°C to 150°C
Power Dissipation	300mW

**SIGNETICS ■ 567 – TONE DECODER PHASE LOCKED LOOP**

**ELECTRICAL CHARACTERISTICS** ( $V+ = 5.0$  Volts,  $T_A = 25^\circ\text{C}$  unless noted)

CHARACTERISTICS	SE567			NE567			UNITS	TEST CONDITIONS
	MIN	TYP	MAX	MIN	TYP	MAX		
<b>CENTER FREQUENCY(NOTE 1)</b>								
Highest Center Frequency ( $f_o$ )	100	500		100	500		kHz	
Center Frequency Stability (Note 2)		35±140 35±60			35±140 35±60		ppm/°C ppm/°C	-55 to 125°C 0 to 70°C
Center Frequency Shift with Supply Voltage		0.5	1		0.7	2	%/Volt	$f_o = 100\text{KHz}$
<b>DETECTION BANDWIDTH</b>								
Largest Detection Bandwidth	12	14	16	10	14	18	% of $f_o$	$f_o = 100\text{KHz}$
Largest Detection Bandwidth Skew		1	2		2	3	% of $f_o$	
Largest Detection Bandwidth – Variation with Temperature		±0.1			±0.1		%/°C	$V_i = 300\text{mVrms}$
Largest Detection Bandwidth – Variation with Supply Voltage		±2			±2		%/Volt	$V_i = 300\text{mVrms}$
<b>INPUT</b>								
Input Resistance		20			20		K $\Omega$	
Smallest Detectable Input Voltage ( $V_i$ )		20	25		20	25	mV rms	$I_L = 100\text{mA}, f_i = f_o$
Largest No-Output Input Voltage	10	15		10	15		mV rms	$I_L = 100\text{mA}, f_i = f_o$
Greatest Simultaneous Outband Signal to Inband Signal Ratio		+6			+6		dB	
Minimum Input Signal to Wideband Noise Ratio		-6			-6		dB	$B_n = 140\text{KHz}$
<b>OUTPUT</b>								
Fastest On-Off Cycling Rate		$f_o/20$			$f_o/20$			
"1" Output Leakage Current		0.01	25		0.01	25	$\mu\text{A}$	
"0" Output Voltage		0.2 0.6	0.4 1.0		0.2 0.6	0.4 1.0	Volt Volt	$I_L = 30\text{mA}$ $I_L = 100\text{mA}$
Output Fall Time (Note 3)		30			30		n sec	$R_L = 50\Omega$
Output Rise Time (Note 3)		150			150		n sec	$R_L = 50\Omega$
<b>GENERAL</b>								
Operating Voltage Range	4.75		9.0	4.75		9.0	Volts	
Supply Current – Quiescent		6	8		7	10	mA	
Supply Current – Activated		11	15		12	15	mA	$R_L = 20\text{K}\Omega$
Quiescent Power Dissipation		30			35		mW	

**NOTES:**

1. Frequency determining resistor  $R_1$  should be between 1 and 20K $\Omega$ .
2. Applicable over 4.75 to 5.75 volts. See graphs for more detailed information.
3. Pin 8 to Pin 1 feedback  $R_L$  network selected to eliminate pulsing during turn-on and turn-off.

TYPICAL CHARACTERISTIC CURVES

**BANDWIDTH VERSUS INPUT SIGNAL AMPLITUDE**

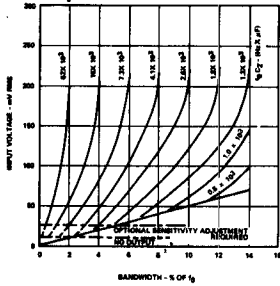

**LARGEST DETECTION BANDWIDTH VERSUS OPERATING FREQUENCY**

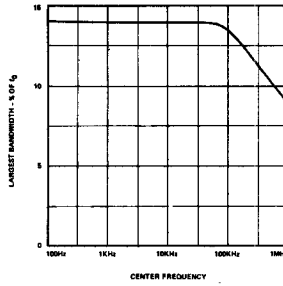

**DETECTION BANDWIDTH AS A FUNCTION OF C2 AND C3**

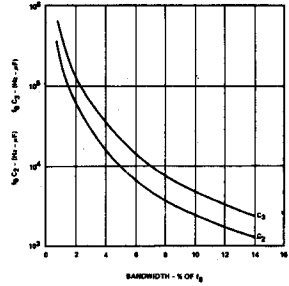

**TYPICAL SUPPLY CURRENT VERSUS SUPPLY VOLTAGE**

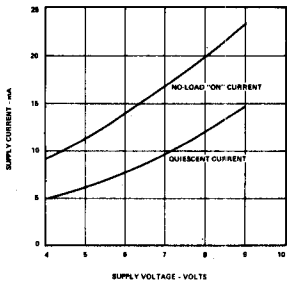

**GREATEST NUMBER OF CYCLES BEFORE OUTPUT**

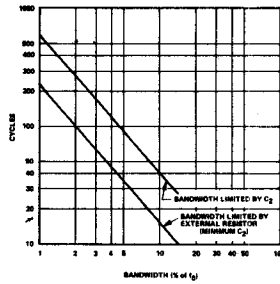

**TYPICAL OUTPUT VOLTAGE VERSUS TEMPERATURE**

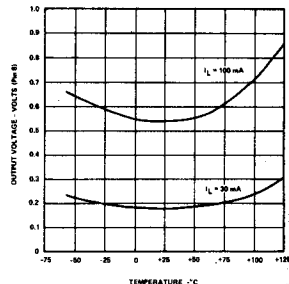

**CENTER FREQUENCY COEFFICIENT TEMPERATURE (MEAN AND S.D.)**

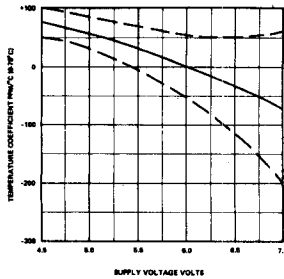

**TYPICAL FREQUENCY DRIFT WITH TEMPERATURE (MEAN AND S.D.)**

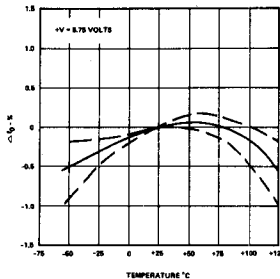

**TYPICAL BANDWIDTH VARIATION WITH TEMPERATURE**

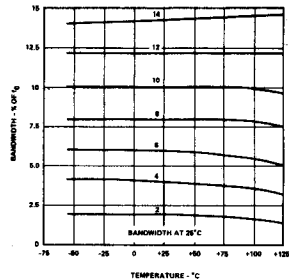

TYPICAL CHARACTERISTIC CURVES (Cont'd.)

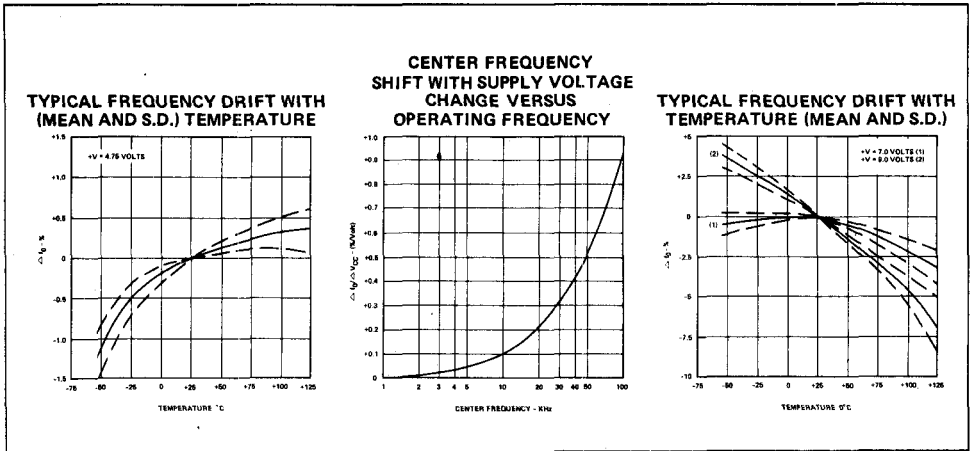

SCHEMATIC DIAGRAM

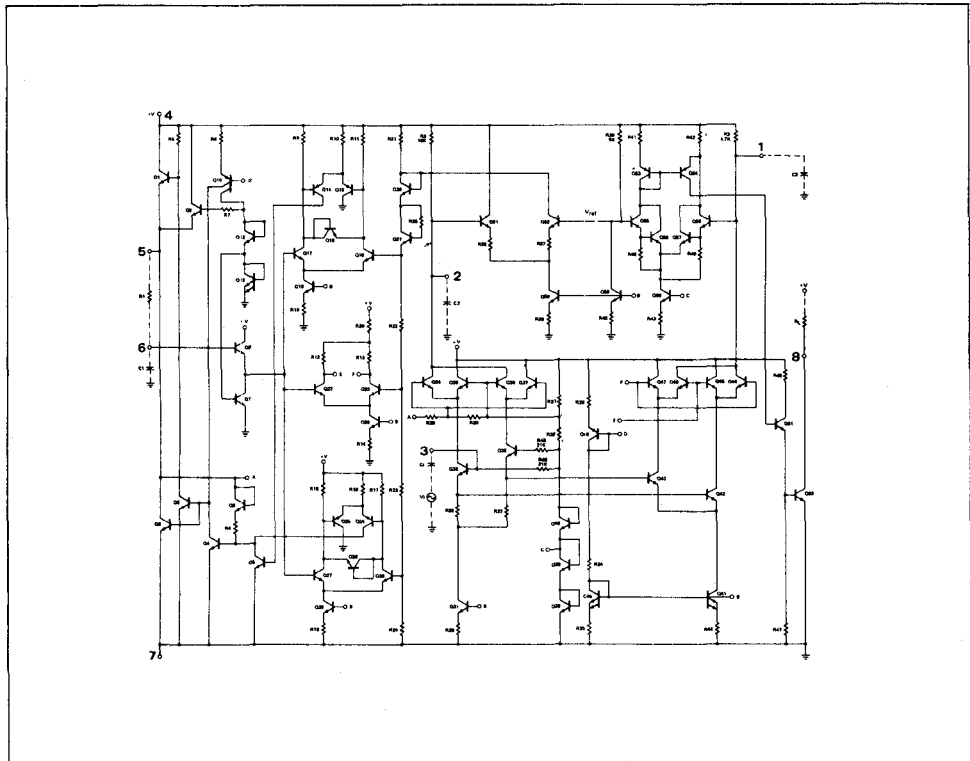

**DESIGN FORMULAS**

$$f_0 \approx \frac{1}{R_1 C_1}$$

$$BW \approx 1070 \sqrt{\frac{V_i}{f_0 C_2}} \text{ in \% of } f_0$$

Where

$V_i$  = Input Voltage (Volts RMS)

$C_2$  = Low-Pass Filter Capacitor ( $\mu\text{F}$ )

**PHASE LOCKED LOOP TERMINOLOGY**
**CENTER FREQUENCY ( $f_0$ )**

The free-running frequency of the current controlled oscillator (CCO) in the absence of an input signal.

**DETECTION BANDWIDTH (BW)**

The frequency range, centered about  $f_0$ , within which an input signal above the threshold voltage (typically 20mV rms) will cause a logical zero state on the output. The detection bandwidth corresponds to the loop capture range.

**LARGEST DETECTION BANDWIDTH**

The largest frequency range within which an input signal above the threshold voltage will cause a logical zero state on the output. The maximum detection bandwidth corresponds to the loop lock range.

**DETECTION BAND SKEW**

A measure of how well the largest detection band is centered about the center frequency,  $f_0$ . The skew is defined as  $(f_{\max} + f_{\min} - 2f_0)/f_0$  where  $f_{\max}$  and  $f_{\min}$  are the frequencies corresponding to the edges of the detection band. The skew can be reduced to zero if necessary by means of an optional centering adjustment.

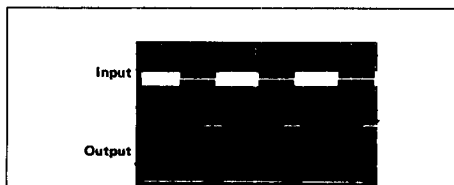
**TYPICAL RESPONSE**

Response to 100mV RMS tone burst.

$R_L = 100$  ohms.

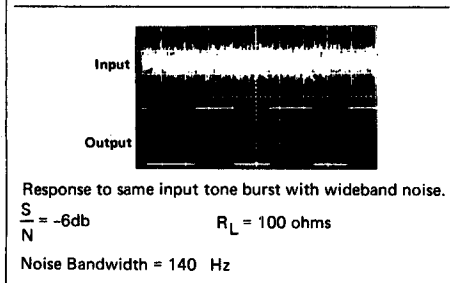

Response to same input tone burst with wideband noise.

$\frac{S}{N} = -6\text{db}$

$R_L = 100$  ohms

Noise Bandwidth = 140 Hz

**OPERATING INSTRUCTIONS**

Figure 1 shows a typical connection diagram for the 567. For most applications, the following three-step procedure will be sufficient for choosing the external components  $R_1$ ,  $C_1$ ,  $C_2$  and  $C_3$ .

1. Select  $R_1$  and  $C_1$  for the desired center frequency ( $f_0 \approx 1/R_1 C_1$ ). For best temperature stability,  $R_1$  should be between 2k and 20k ohm, and the  $R_1 C_1$  product should have sufficient stability, over the projected temperature range to meet the necessary requirements.

2. Select the low-pass capacitor,  $C_2$ , by referring to the Bandwidth versus Input Signal Amplitude graph. If the input amplitude variation is known, the appropriate value of  $f_0 C_2$  necessary to give the desired bandwidth may be found. Conversely, an area of operation may be selected on this graph and the input level and  $C_2$  may be adjusted accordingly. For example, constant bandwidth operation requires that input amplitude be above 200mVrms. The bandwidth, as noted on the graph, is then controlled solely by the  $f_0 C_2$  product.

3. The value of  $C_3$  is generally non-critical.  $C_3$  sets the band edge of a low pass filter which attenuates frequencies outside the detection band to eliminate spurious outputs. If  $C_3$  is too small, frequencies just outside the detection band will switch the output stage on and off at the beat frequency, or the output may pulse on and off during the turn-on transient. If  $C_3$  is too large, turn-on and turn-off of the output stage will be delayed until the voltage on  $C_3$  passes the threshold voltage. (Such a delay may be desirable to avoid spurious outputs due to transient frequencies.) A typical minimum value for  $C_3$  is  $2C_2$ .

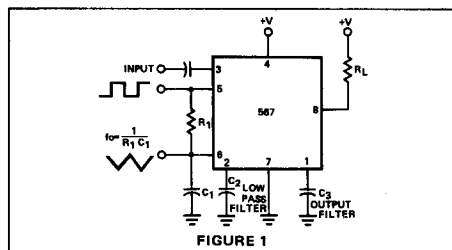

FIGURE 1

**AVAILABLE OUTPUTS (Figure 2)**

The primary output is the uncommitted output transistor collector, pin 8. When an in-band input signal is present, this transistor saturates; its collector voltage being less than 1.0 volt (typically 0.6V) at full output current (100mA).

The voltage at pin 2 is the phase detector output, a linear function of frequency, over the range of 0.95 to 1.05  $f_0$ , with a slope of about 20mV/% frequency deviation. The average voltage at pin 1 is, during lock, a function of the in-band input amplitude in accordance with the transfer characteristic given. Pin 5 is the controlled oscillator square wave output of magnitude  $(V^+ - 2V_{be}) \approx (V^+ - 1.4V)$  having a dc average of  $V^+/2$ . A 1K $\Omega$  load may be driven from pin 5. Pin 6 is an exponential triangle of 1 volt peak-to-peak

**AVAILABLE OUTPUTS (Cont'd.)**

with an average dc level of  $V^+ / 2$ . Only high impedance loads may be connected to pin 6 without affecting the CCO duty cycle or temperature stability.

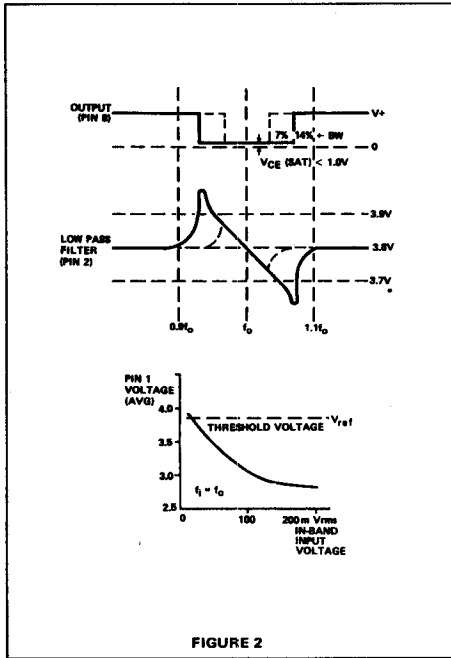

FIGURE 2

**OPERATING PRECAUTIONS**

A brief review of the following precautions will help the user attain the high level of performance of which the 567 is capable.

1. Operation in the high input level mode (above 200mV) will free the user from bandwidth variations due to changes in the in-band signal amplitude. The input stage is now limiting, however, so that out-band signals or high noise levels can cause an apparent bandwidth reduction as the in band signal is suppressed. Also, the limiting action will create in-band components from sub-harmonic signals, so the 567 becomes sensitive to signals at  $f_o/3$ ,  $f_o/5$ , etc.
2. The 567 will lock onto signals near  $(2n+1) f_o$ , and will give an output for signals near  $(4n+1) f_o$  where  $n = 0, 1, 2$ , etc. Thus, signals at  $5 f_o$  and  $9 f_o$  can cause an unwanted output. If such signals are anticipated, they should be attenuated before reaching the 567 input.
3. Maximum immunity from noise and out-band signals is afforded in the low input level (Below 200mVrms) and reduced bandwidth operating mode. However, decreased loop damping causes the worst-case lock-up time to increase, as shown by the Greatest Number of Cycles Before Output vs. Bandwidth graph.

4. Due to the high switching speeds (20ns) associated with 567 operation, care should be taken in lead routing. Lead lengths should be kept to a minimum. The power supply should be adequately bypassed close to the 567 with an  $0.01\mu F$  or greater capacitor; grounding paths should be carefully chosen to avoid ground loops and unwanted voltage variations. Another factor which must be considered is the effect of load energization on the power supply. For example, an incandescent lamp typically draws 10 times rated current at turn-on. This can cause supply voltage fluctuations which could, for example, shift the detection band of narrow-band systems sufficiently to cause momentary loss of lock. The result is a low-frequency oscillation into and out of lock. Such effects can be prevented by supplying heavy load currents from a separate supply, or increasing the supply filter capacitor.

**SPEED OF OPERATION**

Minimum lock-up time is related to the natural frequency of the loop. The lower it is, the longer becomes the turn-on transient. Thus, maximum operating speed is obtained when  $C_2$  is at a minimum. When the signal is first applied, the phase may be such as to initially drive the controlled oscillator away from the incoming frequency rather than toward it. Under this condition, which is of course unpredictable, the lock-up transient is at its worst and the theoretical minimum lock-up time is not achievable. We must simply wait for the transient to die out.

The following expressions give the values of  $C_2$  and  $C_3$  which allow highest operating speeds for various band center frequencies. The minimum rate at which digital information may be detected without information loss due to the turn-on transient or output chatter is about 10 cycles per bit, corresponding to an information transfer rate of  $f_o/10$  baud.

$$C_2 = \frac{130}{f_o} \mu F$$

$$C_3 = \frac{260}{f_o} \mu F$$

in cases where turn-off time can be sacrificed to achieve fast turn-on, the optional sensitivity adjustment circuit can be used to move the quiescent  $C_3$  voltage lower (closer to the threshold voltage). However, sensitivity to beat frequencies, noise and extraneous signals will be increased.

**OPTIONAL CONTROLS**

The 567 has been designed so that, for most applications, no external adjustments are required. Certain applications, however, will be greatly facilitated if full advantage is taken of the added control possibilities available through the use of additional external components. In the diagrams given, typical values are suggested where applicable. For best results resistors used, except where noted, should have the same temperature coefficient. Ideally, silicon diodes would be low-resistivity types, such as forward-biased low-voltage zeners or forward-biased transistor base-emitter junctions. However, ordinary low-voltage diodes should be adequate for most applications.

**SENSITIVITY ADJUSTMENT**

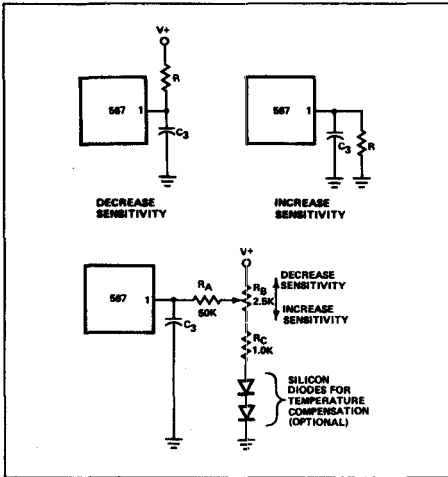

When operated as a very narrow band detector (less than 8 percent), both  $C_2$  and  $C_3$  are made quite large in order to improve noise and outband signal rejection. This will inevitably slow the response time. If, however, the output stage is biased closer to the threshold level, the turn-on time can be improved. This is accomplished by drawing additional current to terminal 1. Under this condition, the 567 will also give an output for lower-level signals (10m or lower).

By adding current to terminal 1, the output stage is biased further away from the threshold voltage. This is most useful when, to obtain maximum operating speed,  $C_2$  and  $C_3$  are made very small. Normally, frequencies just outside the detection band could cause false outputs under this condition. By desensitizing the output stage, the outband beat notes do not feed through to the output stage. Since the input level must be somewhat greater when the output stage is made less sensitive, rejection of third harmonics or in-band harmonics (of lower frequency signals) is also improved.

**CHATTER PREVENTION**

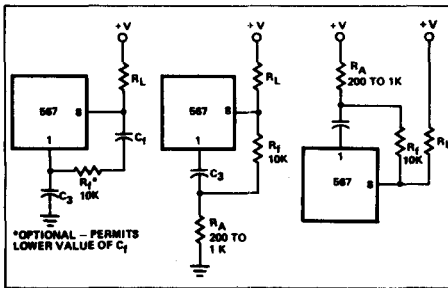

Chatter occurs in the output stage when  $C_3$  is relatively small, so that the lock transient and the AC components at the quadrature phase detector (lock detector) output cause the output stage to move through its threshold more than once. Many loads, for example lamps and relays, will not respond to the chatter. However, logic may recognize the chatter as a series of outputs. By feeding the output stage output back to its input, (pin 1) the chatter can be eliminated. Three schemes for doing this are given above. All operate by feeding the first output step (either on or off) back to the input, pushing the input past the threshold until the transient conditions are over. It is only necessary to assure that the feedback time constant is not so large as to prevent operation at the highest anticipated speed. Although chatter can always be eliminated by making  $C_3$  large, the feedback circuit will enable faster operation of the 567 by allowing  $C_3$  to be kept small. Note that if the feedback time constant is made quite large, a short burst at the input frequency can be stretched into a long output pulse. This may be useful to drive, for example, stepping relays.

**DETECTION BAND CENTERING (OR SKEW) ADJUSTMENT**

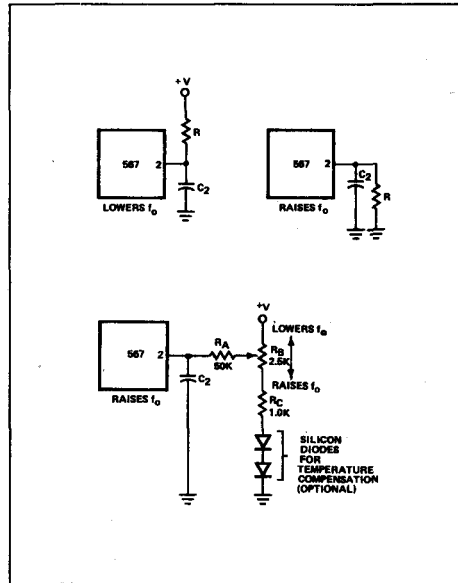

When it is desired to alter the location of the detection band (corresponding to the loop capture range) within the largest detection band (lock range), the circuits shown above can be used. By moving the detection band to one edge of the range, for example, input signal variations will expand the detection band in only one direction. This may prove useful when a strong but undesirable signal is expected on one side or the other of the center frequency. Since  $R_B$  also alters the duty cycle slightly, this method may be used to obtain a precise duty cycle when the 567 is used as an oscillator.

ALTERNATE METHOD OF BANDWIDTH REDUCTION

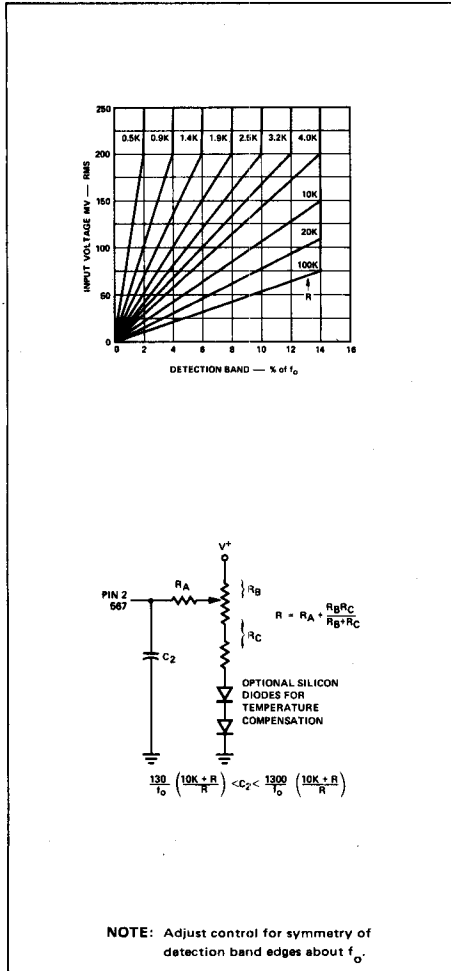

Although a large value of  $C_2$  will reduce the bandwidth, it also reduces the loop damping so as to slow the circuit response time. This may be undesirable. Bandwidth can be reduced by reducing the loop gain. This scheme will improve damping and permit faster operation under narrow band operation. Note that the reduced impedance level at terminal 2 will require that a larger value of  $C_2$  be used for a given filter cutoff frequency. If more than three 567s are to be used, the  $R_B$ ,  $R_C$  network can be eliminated and the  $R_A$  resistors connected together. A capacitor between this junction and ground may be required to shunt high frequency components.

OUTPUT LATCHING

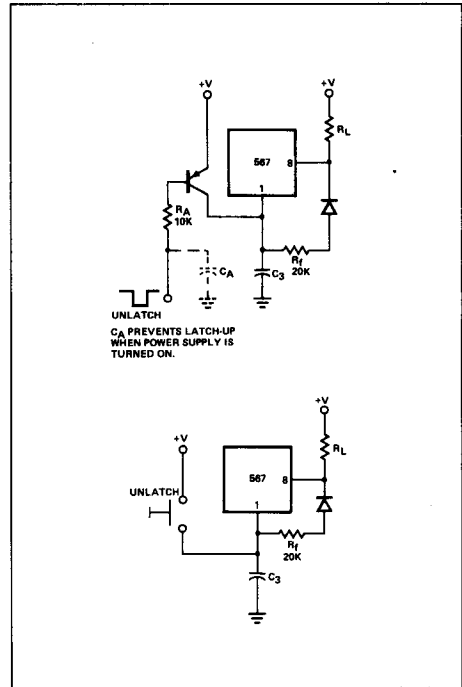

To latch the output on after a signal is received, it is necessary to provide a feedback resistor around the output stage (between pins 8 and 1). Pin 1 is pulled up to unlatch the output stage.

REDUCTION OF  $C_1$  VALUE

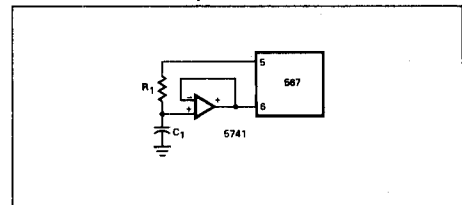

For precision, very low-frequency applications, where the value of  $C_1$  becomes large, an overall cost savings may be achieved by inserting a voltage follower between the  $R_1$   $C_1$  junction and pin 6, so as to allow a higher value of  $R_1$  and a lower value of  $C_1$  for a given frequency.

PROGRAMMING

To change the center frequency, the value of  $R_1$  can be changed with a mechanical or solid state switch, or additional  $C_1$  capacitors may be added by grounding them through saturating npn transistors.



TYPICAL APPLICATIONS

CARRIER-CURRENT REMOTE CONTROL OR INTERCOM

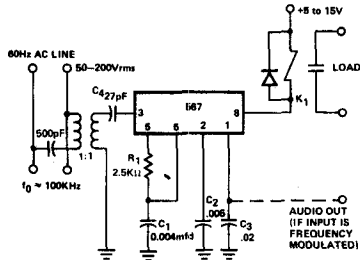

DUAL-TONE DECODER

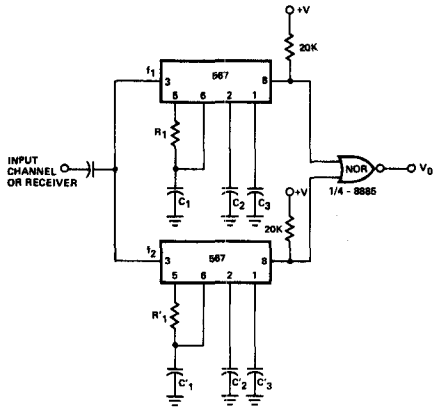

1. Resistor and capacitor values chosen for desired frequencies and bandwidth.
2. If  $C_3$  is made large so as to delay turn-on of the top 567, decoding of sequential ( $f_1, f_2$ ) tones is possible.

TOUCH-TONE® DECODER

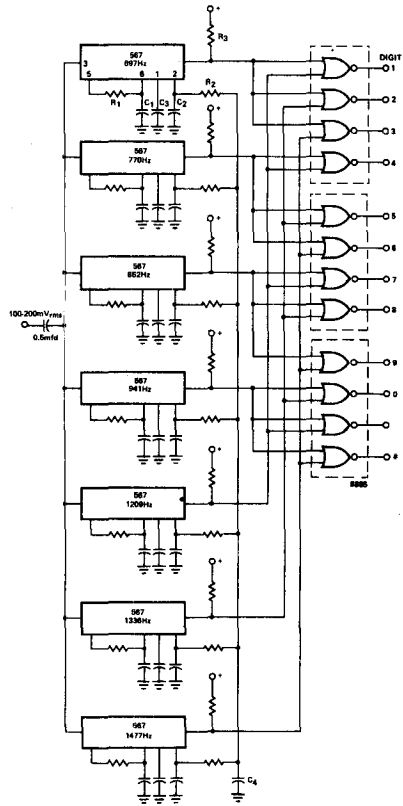

Component Values (Typical)

- $R_1$  6.8 to 15K ohm
- $R_2$  4.7K ohm
- $R_3$  20K ohm
- $C_1$  0.10 mfd
- $C_2$  1.0 mfd 6V
- $C_3$  2.2mfd 6V
- $C_4$  250 6V

TYPICAL APPLICATIONS (Cont'd.)

