

# T B 3 1 2 0 2 F N G

## PLL FREQUENCY SYNTHESIZER

### FEATURES

- One packaging two systems prescaler and PLL for receiver and transmitter
- Low operating power supply voltage :  $V_{CC} = 2.0 \sim 5.5V$   
(Temperature  $\geq -10^{\circ}C$  :  $V_{CC} = 1.9 \sim 5.5V$ )
- Low current consumption :  $I_{CC} = 8mA$  (Typ.)
- Input frequency :  $f_{IN} = 200 \sim 520MHz$
- High input sensitivity :  $V_{IN} = 93 \sim 107dB\mu V$
- Charge pump is constant current type, and is able to change output current by serial data
- Reference oscillation circuit is adopted circuit of bipolar, so getting the stable X'tal oscillation circuit
- Available standby control for receiver and transmitter independent of each other
- The very small package : SSOP16pin (0.65mm pitch)

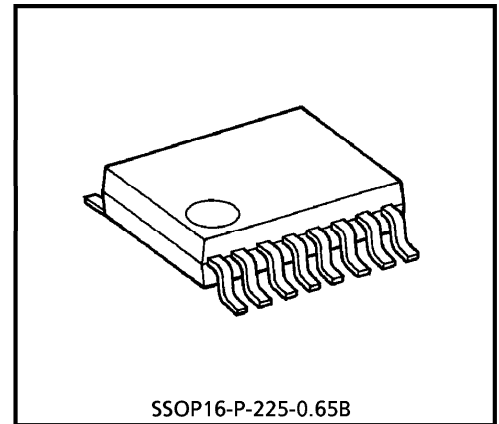

Weight : 0.07g (Typ.)

### BLOCK DIAGRAM

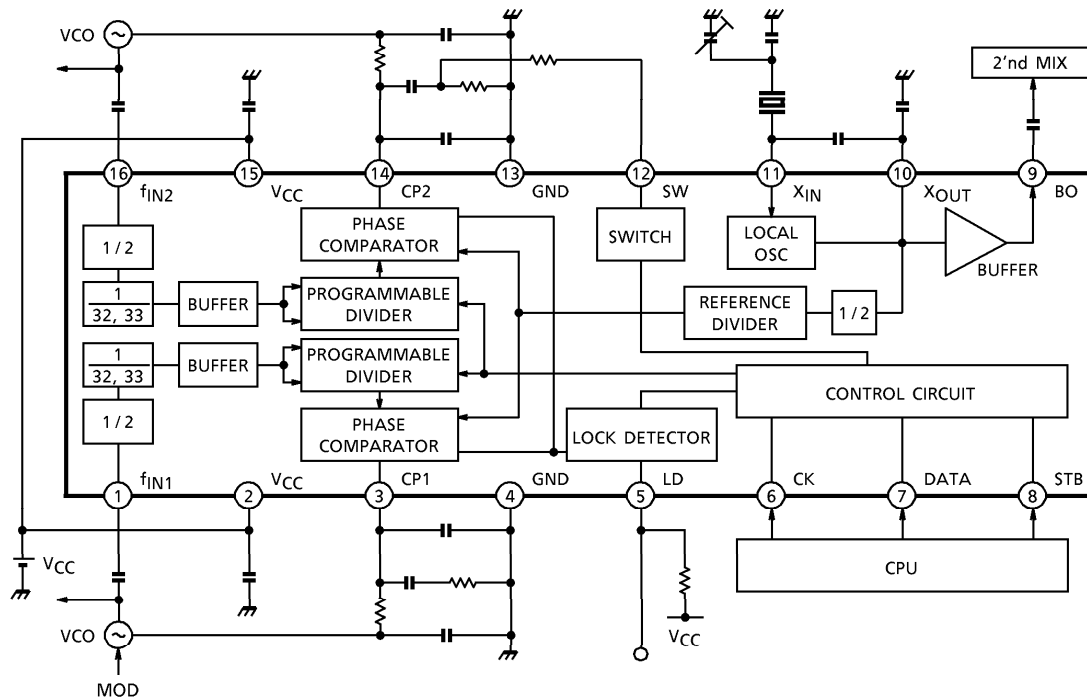

:The TB31202FNG Package is Pb-Free.

**PIN FUNCTION** (The values of resistor and capacitor are typical.)

PIN No.	PIN NAME	FUNCTION	INTERNAL EQUIVALENT CIRCUIT
1	f <sub>IN1</sub>	Input terminal of RF oscillation signal.	
16	f <sub>IN2</sub>		
2	V <sub>CC</sub>	Terminal of power supply.	
15	V <sub>CC</sub>	Pin 2 and pin 15 are connected in IC.	
3	CP1	Output terminal of charge pump. Charge pump is constant current output circuit, and output current is varied by input serial data.	
14	CP2		
4	GND	Terminal of GND.	
13	GND	Pin 4 and pin 13 are connected in IC.	
5	LD	Output terminal of lock detection. It is the open drain output.	
12	SW	Switchover terminal for constant of loop filter. It is the open drain output. When don't switch constant of loop filter, available general output.	
6	CK	Input terminal of clock.	
7	DATA	Input terminal of serial data.	
8	STB	Input terminal of strobe signal.	
9	BO	Output terminal of buffer amplifier. The signal of local oscillation is output through the buffer amplifier.	
10	X <sub>OUT</sub>	Output terminal of local oscillation signal.	
11	X <sub>IN</sub>	Input terminal of local oscillation signal. In case of external input, connecting it to this terminal.	

**DESCRIPTION OF FUNCTION AND OPERATION**

1. Entry of serial data

- Serial data used to control the IC is input through three terminals, CK, DATA and STB.
  - ① During the rise of a clock pulse, data is fed to the shift register in the IC in order from the LSB.
  - ② Upon the reception of all data, the strobe signal (STB) is made "H".
  - ③ After the reception of a strobe signal (STB) of the "H" level, the data stored in the shift register is transferred to the latch in the block selected by the group code, whereby the IC is controlled.
- The three terminal, CK, DATA and STB, contains Schmitt trigger circuits to prevent the data errors by noise, etc.

○ Serial data group and group code

- The IC has control divided into four groups so that they may be controlled independent of one another. Each group is identified by a 2bit group code attached at the data end.

CODE	ITEM
10	Number of divisions by CH1 programmable divider ( $f_{IN1}$ )
01	Number of divisions by CH2 programmable divider ( $f_{IN2}$ )
11	Number of divisions by reference divider ( $X_{IN}$ )
00	Optional control

○ Serial data input timing

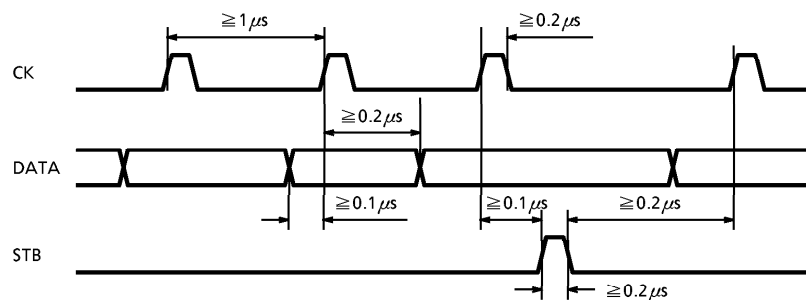

2. Programmable dividers (CH1, CH2)

- These programmable dividers are composed of a 5bit swallow counter (5bit programmable divider), a 12bit programmable counter, and a two-modular prescaler providing 64 and 66 divisions.
- The strategy of a swallow counter is used to set high reference frequency.
- Sending certain data to the swallow counter and the programmable counter allows the setting of any of 2048 to 262142 divisions (multiple of two).
- The programmable counter and swallow counter are set by each channel. Each channel is specified by a group code.

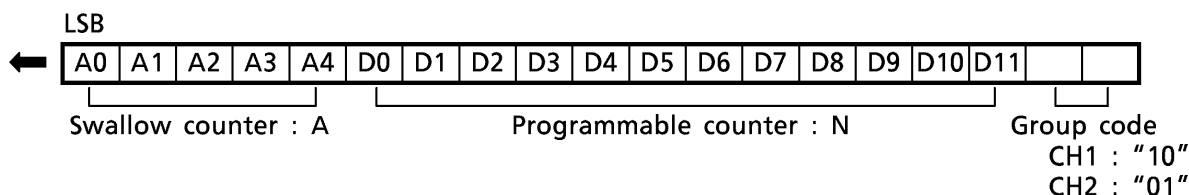

$$\left\{ \begin{array}{l} A = A_0 + A_1 \times 2^1 + \dots + A_4 \times 2^4 \\ N = D_0 + D_1 \times 2^1 + \dots + D_{11} \times 2^{11} \\ \text{Number of divisions} = 2(32N + A) \\ 2048 \leq \text{Number of divisions} \leq 262142 \end{array} \right. \quad \left\{ \begin{array}{l} N : \text{Value of N counter} \\ A : \text{Value of A counter} \end{array} \right.$$

(EX) A Signal of 380MHz is entered into  $f_{IN1}$ , being divided into 12.5MHz step.  
(Reference frequency is 6.25kHz)

$$\begin{aligned} 380 \times 10^6 \div (12.5 \times 10^3 \div 2) &= 60800 \\ 60800 &= 2(32N + A) \\ \therefore N &= 950, A = 0 \end{aligned}$$

3. Reference divider

- This block generates the reference frequency for the PLL.
- The reference divider is composed of a 12bit reference divider and a half fixed divider.
- Sending certain data to the reference divider allows the setting of any of 16 to 8190 divisions (multiple of two).

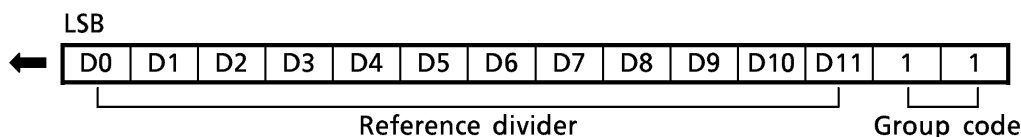

$$\left\{ \begin{array}{l} D = D_0 + D_1 \times 2^1 + \dots + D_{10} \times 2^{10} + D_{11} \times 2^{11} \\ \text{Number of divisions} = 2D \\ 16 \leq \text{Number of divisions} \leq 8190 \end{array} \right.$$

(EX) With a 21.25MHz X'tal oscillator connected, being divided into 12.5kHz step.  
(Reference frequency is 6.25kHz)

$$\begin{aligned} 21.25 \times 10^6 \div (12.5 \times 10^3 \div 2) &= 3400 \\ 3400 &= 2D \\ \therefore D &= 1700 \end{aligned}$$

4. Optional control

- The optional control below is available.
  - ① Test mode (Usually set up T = "0").
  - ② Control and polarity control of the charge pump output current for each channel.
  - ③ Output terminal for Lock detector.
  - ④ Standby control of each channel and reference divider.
  - ⑤ Control of filter switch.

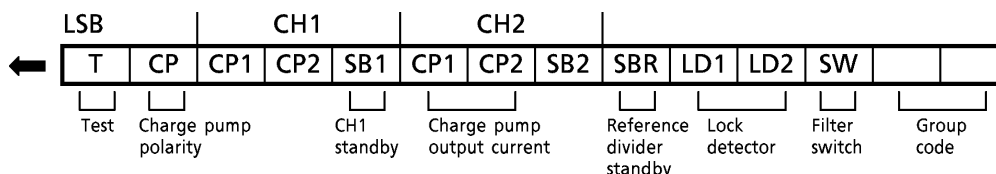

- T : Bit for test mode
- CP : Switchover bit for charge pump output polarity
- CP1, 2 : Switchover bit for charge pump output current
- SB1, 2 : Standby control bit for CH1, CH2
- SBR : Standby control bit for reference divider
- LD1, 2 : Control bit for lock detector output
- SW : Control bit for filter switch

● Description of options including their control

① Test mode (T)

Bit "T" is for test mode. In other than the test mode, set this bit at "0".

② Control of charge pump output current (CP1, CP2)

This IC uses a constant current output type charge pump circuit. Output current is varied by controlling "CP1" and "CP2".

CHARGE PUMP OUTPUT CURRENT

CONTROL BIT		CHARGE PUMP OUTPUT CURRENT
CP1	CP2	
0	0	± 100 μA
0	1	± 200 μA
1	0	± 400 μA
1	1	± 800 μA

High speed lock up is possible by switching charge pump output current.

(Note)

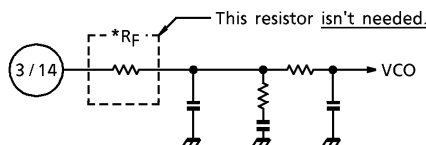

Charge pump output polarity (CP)

Bit "CP" can be reversed charge pump output polarity.

**CHARGE PUMP OUTPUT POLARITY**

CP	OUTPUT POLARITY
0	Normal
1	Reverse

③ Lock detector output

When phase comparator detects phase difference, LD terminal (pin 5) outputs "L". When phase comparator locks, LD terminal outputs "H". On standby, outputs "H".

LD terminal output is controlled by "SB1", "SB2", "LD1" and "LD2".

CONTROL BIT				LOCK DETECTOR OUTPUT STATE
SB1	SB2	LD1	LD2	
0	0	0	0	L
		0	1	CH2 only detect
		1	0	CH1 only detect
		1	1	CH1 * CH2
0	1	0	0	L
		0	1	H
		1	0	CH1 only detect
		1	1	CH1 only detect
1	0	0	0	L
		0	1	CH2 only detect
		1	0	H
		1	1	CH2 only detect
1	1	0	0	L
		0	1	H
		1	0	H
		1	1	H

Logical multiply (AND) of CH1, CH2

About SB1, SB2 bit  
 0 : Normal operation  
 1 : Standby

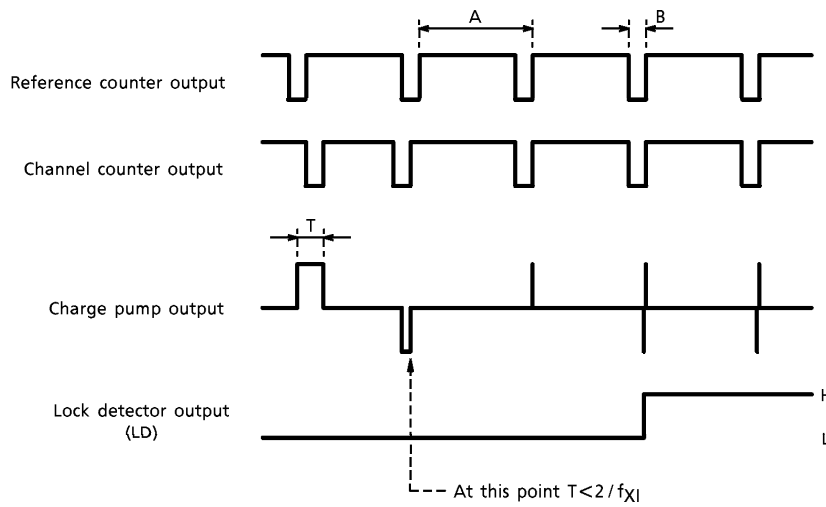

$f_{XI}$  :  $X_{IN}$  operating frequency (LOCAL OSC)

T : The time difference of the pulse between reference counter output and channel counter output.

$$A = \frac{\text{Number of divisions by reference divider}}{f_{XI}} \text{ (s)}$$

$$B = 2 / f_{XI} \text{ (s)}$$

When the situation that T is less than  $2 / f_{XI}$  ( $T < 2 / f_{XI}$ ) continues more than three cycles of reference counter output, lock detector outputs "H".

④ Standby control (SB1, SB2, SBR)

Standby control by three bits (SB1, SB2, SBR).

Bits "SB1" and "SB2" do standby control of CH1, CH2. Bit "SBR" does standby control of reference divider.

CONTROL BIT			STATE		
SB1	SB2	SBR	CH1	CH2	REF
0	0	*	ON	ON	ON
0	1	*	ON	OFF	ON
1	0	*	OFF	ON	ON
1	1	0	OFF	OFF	ON
1	1	1	OFF	OFF	OFF

Interlocking mode

REF ON mode

## ⑤ Filter switch control (SW)

Control of SW terminal by bit "SW".

This terminal is for switching constant of loop filter.

Output type of this terminal is open drain output. Switching the register of loop filter by this terminal with switching charge pump output current, high mode and normal mode can operate PLL by ideal braking factor.

When constant of loop filter don't change switch, available general output.

FILTER SWITCH CONTROL

SW	OUTPUT
0	OFF
1	ON

## 5. Reference frequency oscillation circuit and buffer amplifier

This IC has a stable oscillation circuit composed of bipolar.

In case of inputting the external reference frequency directly, use X<sub>IN</sub> terminal (pin 11).

For the common use of X'tal of the reference frequency oscillation circuit for the PLL and X'tal of local oscillation to 2'nd MIX, output terminal of local oscillation signal with buffer amplifier (pin 9) may be used.

This terminal (pin 9) is provided with a buffer amplifier.



**MAXIMUM RATINGS** (Ta = 25°C)

CHARACTERISTIC	SYMBOL	RATING	UNIT
Power Supply Voltage	V <sub>CC</sub>	6	V
Power Dissipation	P <sub>D</sub>	560	mW
Operating Temperature	T <sub>opr</sub>	-30~85	°C
Storage Temperature	T <sub>stg</sub>	-55~150	°C

**ELECTRICAL CHARACTERISTIC**(Unless otherwise specified, V<sub>CC</sub> = 2.2V, Ta = 25°C)

CHARACTERISTIC	SYMBOL	TEST CIR-CUIT	TEST CONDITION	MIN.	TYP.	MAX.	UNIT
Operating Power Supply Voltage	V <sub>CC</sub>		Ta = -30~85°C	2.0	2.2	5.5	V
			Ta = -10~85°C	1.9	2.2	5.5	
Operating Current Consumption	I <sub>CCO</sub>		CH1 = CH2 = 300MHz, 107dB $\mu$ V input	5.0	8.0	11.0	mA
Current Consumption	I <sub>CCQ</sub>		At standby mode	—	0	10	$\mu$ A
f <sub>IN</sub> Operating Frequency	f <sub>IN1</sub>		V <sub>IN1</sub> = 93dB $\mu$ V	200	—	520	MHz
	f <sub>IN2</sub>		V <sub>IN2</sub> = 93dB $\mu$ V	200	—	520	
f <sub>IN</sub> Input Sensitivity	V <sub>IN1</sub>		f <sub>IN1</sub> = 200~520MHz	93	—	107	dB $\mu$ V
	V <sub>IN2</sub>		f <sub>IN2</sub> = 200~520MHz	93	—	107	
X <sub>IN</sub> Operating Frequency	f <sub>XI</sub>		V <sub>X</sub> = 0.5V <sub>p-p</sub> , Sin-wave	5	21.25	25	MHz
X <sub>IN</sub> Input Voltage	V <sub>XI</sub>		f <sub>XI</sub> = 21.25MHz	102	107	112	dB $\mu$ V
Input Voltage	V <sub>IH</sub>		STB, DATA, CK	V <sub>CC</sub> × 0.8	V <sub>CC</sub>	5.7	V
	V <sub>IL</sub>		STB, DATA, CK	-0.2	0	V <sub>CC</sub> × 0.2	
CK Input Frequency	f <sub>CK</sub>		CK	—	—	1	MHz
Charge Pump Output Current	I <sub>CP1</sub>		"CP1" = 0, "CP2" = 0, V <sub>CP</sub> = 1.1V	—	± 100	—	$\mu$ A
	I <sub>CP2</sub>		"CP1" = 0, "CP2" = 1, V <sub>CP</sub> = 1.1V	—	± 200	—	
	I <sub>CP3</sub>		"CP1" = 1, "CP2" = 0, V <sub>CP</sub> = 1.1V	—	± 400	—	
	I <sub>CP4</sub>		"CP1" = 1, "CP2" = 1, V <sub>CP</sub> = 1.1V	—	± 800	—	
Charge Pump OFF Leak Current	C <sub>POFF</sub>		Standby mode, V <sub>CP</sub> = 1.1V	—	—	± 1.0	$\mu$ A
SW Terminal ON Resistance	R <sub>SW</sub>		SW <sub>ON</sub>	—	500	—	$\Omega$
LD Terminal ON Resistance	R <sub>LD</sub>		LD <sub>ON</sub>	—	500	—	$\Omega$
SW Terminal OFF Leak Current	SW <sub>OFF</sub>		SW <sub>OFF</sub>	—	—	± 1.0	$\mu$ A
LD Terminal OFF Leak Current	LD <sub>OFF</sub>		LD <sub>OFF</sub>	—	—	± 1.0	$\mu$ A

REFERENCE DATA (Typ.)

CH1	CH2	REFERENCE DIVIDER	CURRENT CONSUMPTION	UNIT
N	N	ON	8.0	mA
N	S	ON	4.5	mA
S	N	ON	4.5	mA
S	S	ON	800	$\mu$ A
S	S	OFF	0	$\mu$ A

A : Normal operation  
S : Standby state

TEST CIRCUIT

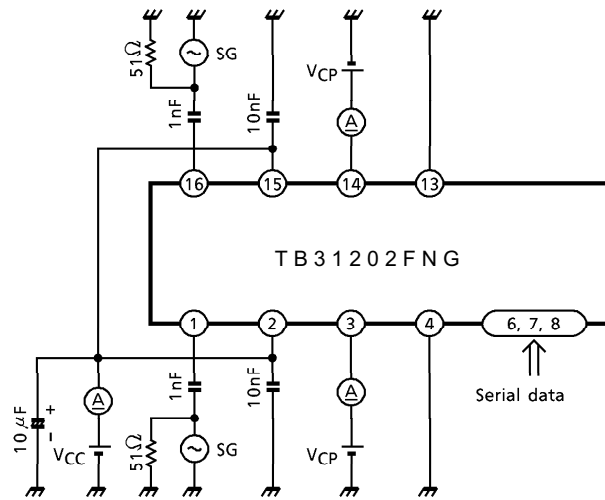

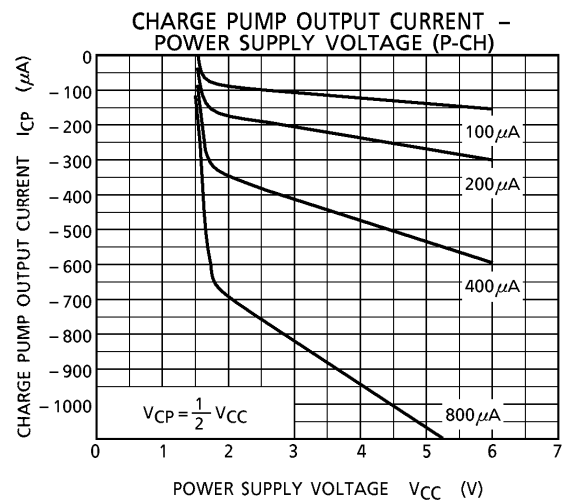
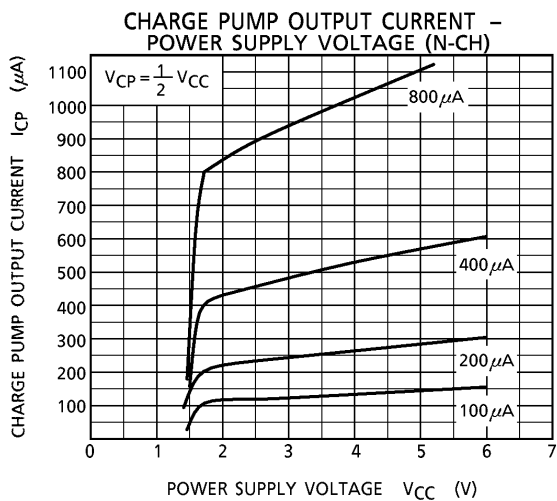
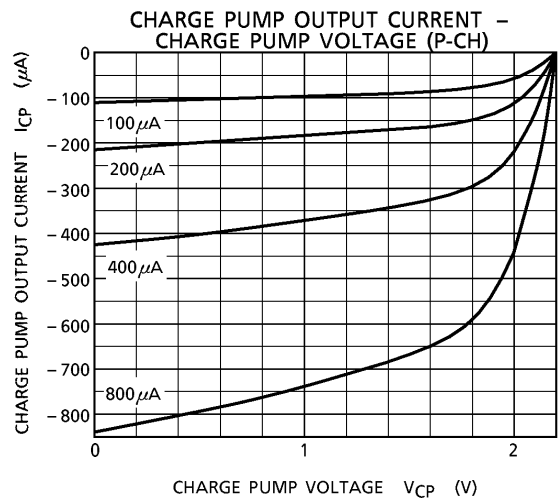
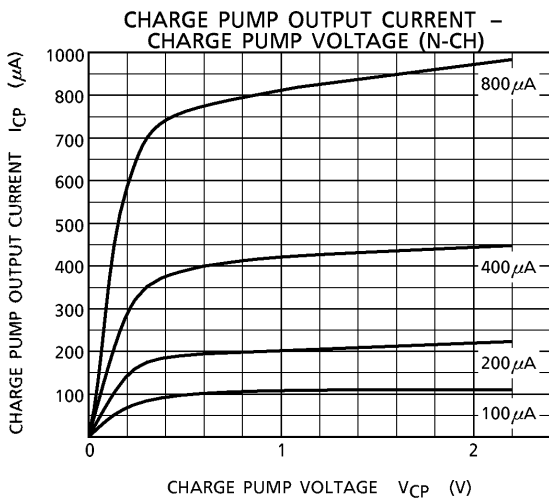
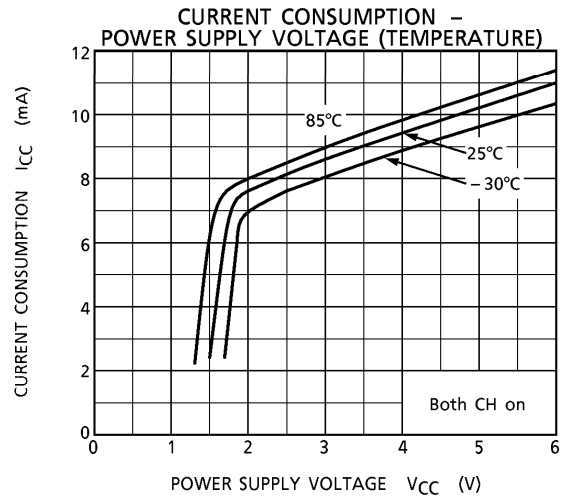
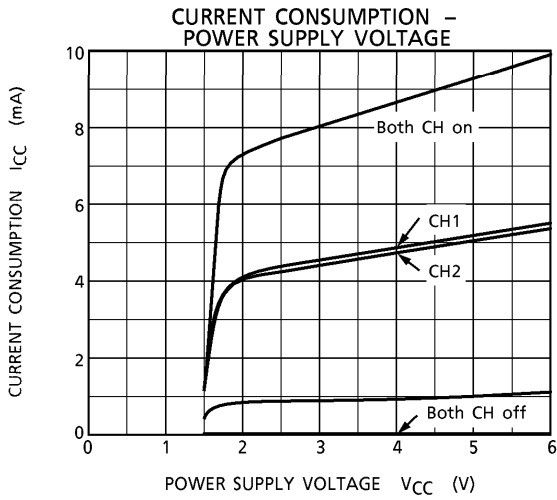

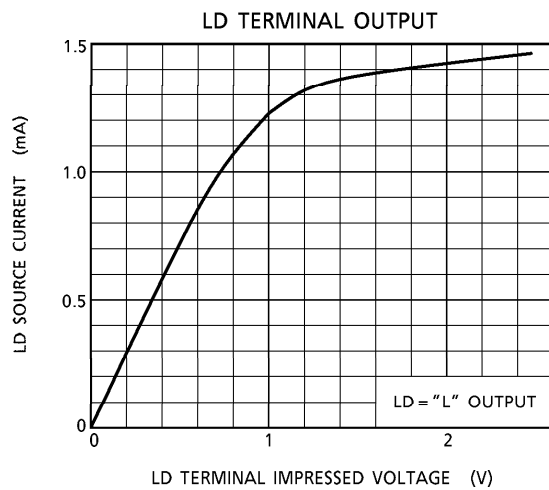
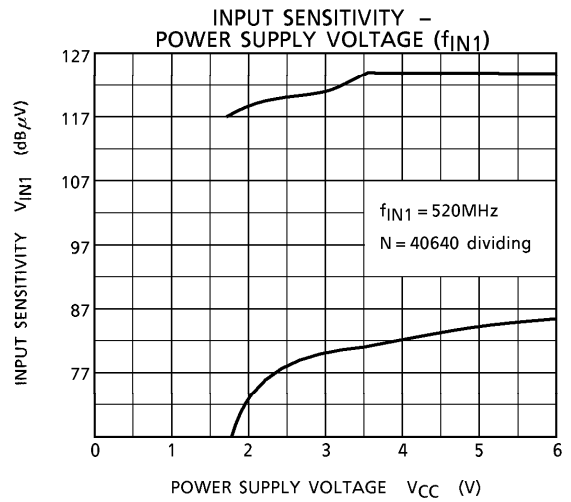
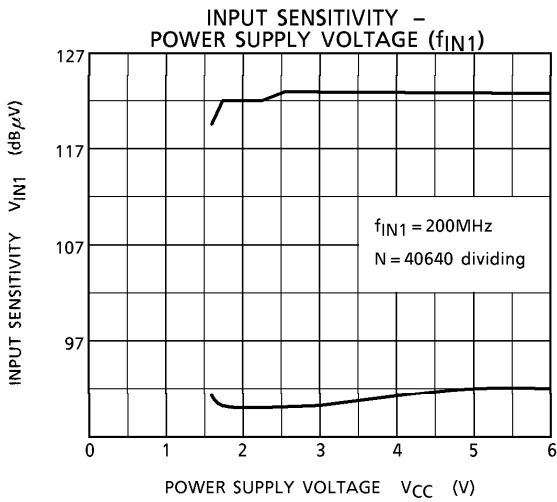
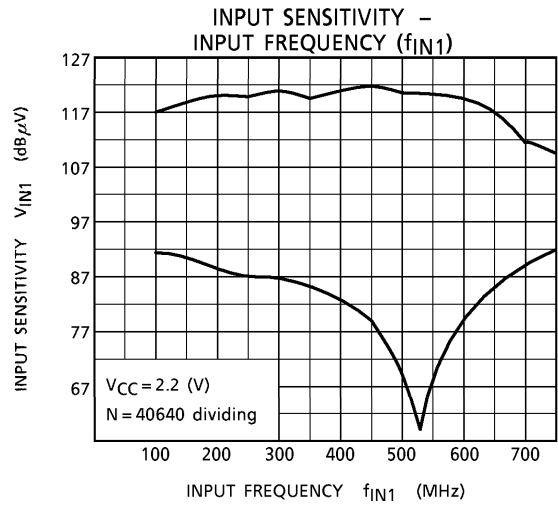
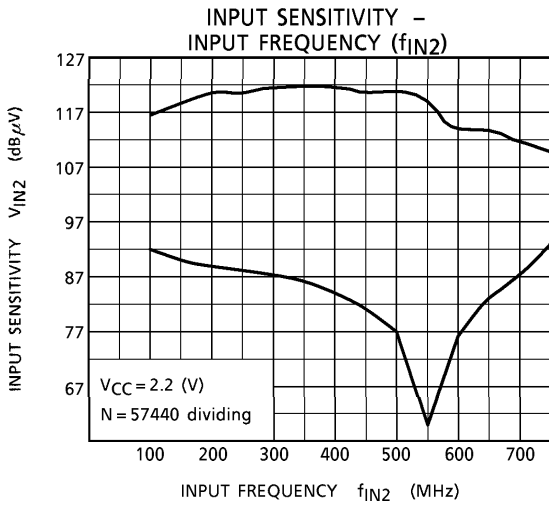

APPLICATION CIRCUIT

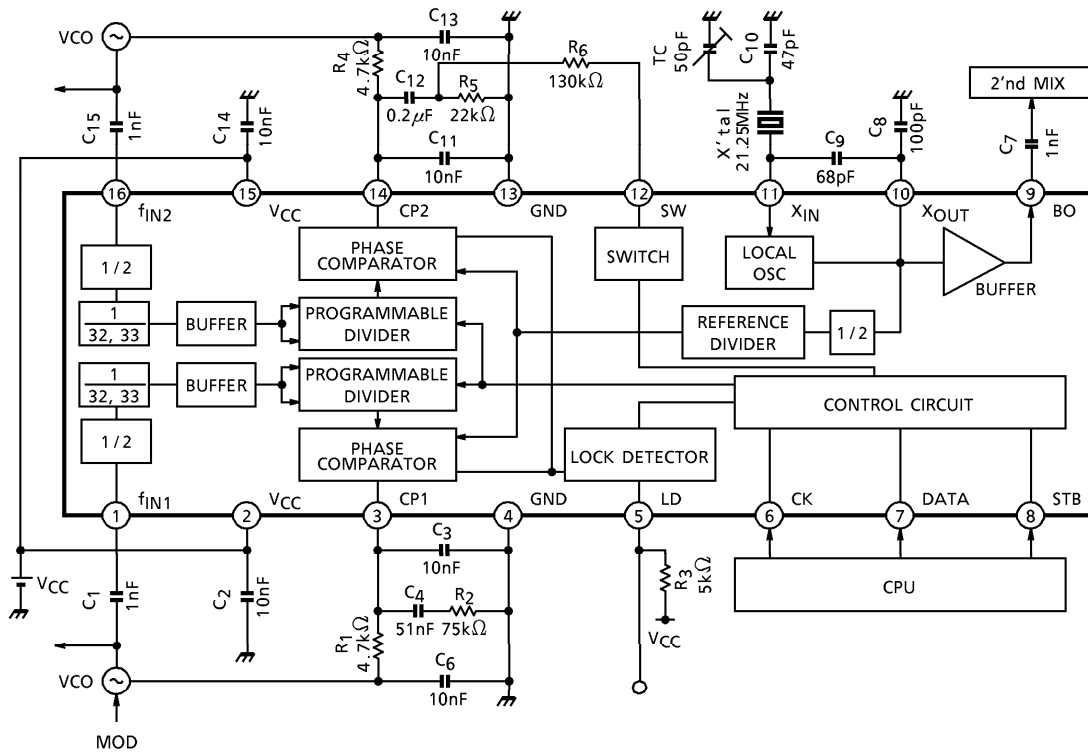

PACKAGE DIMENSIONS  
SSOP16-P-225-0.65B

Unit : mm

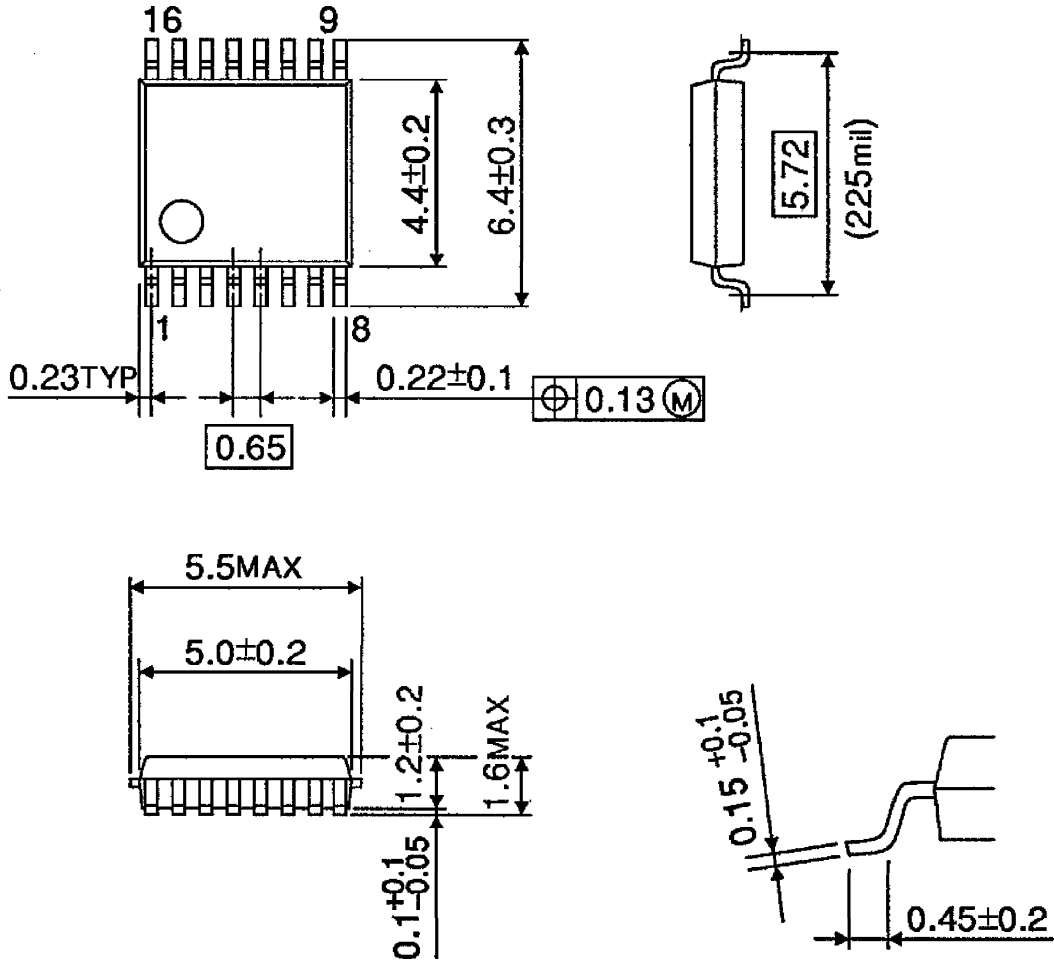

Weight : 0.07g (Typ.)

## Notice for Pb free product

About solderability, following conditons were confirmed.

## Solderability

- (1) Use of Sn-36Pb solder bath
  - solder bath temperature = 230
  - dipping time = 5seconds
  - the number of times = once
  - use of R-type flux
- (2) Use of Sn-3.0Ag-0.5Cu solder bath
  - solder bath temperature = 245
  - dipping time = 5seconds
  - the number of times = once
  - use of R-type flux

**RESTRICTIONS ON PRODUCT USE**

000707EBA

- TOSHIBA is continually working to improve the quality and reliability of its products. Nevertheless, semiconductor devices in general can malfunction or fail due to their inherent electrical sensitivity and vulnerability to physical stress. It is the responsibility of the buyer, when utilizing TOSHIBA products, to comply with the standards of safety in making a safe design for the entire system, and to avoid situations in which a malfunction or failure of such TOSHIBA products could cause loss of human life, bodily injury or damage to property. In developing your designs, please ensure that TOSHIBA products are used within specified operating ranges as set forth in the most recent TOSHIBA products specifications. Also, please keep in mind the precautions and conditions set forth in the "Handling Guide for Semiconductor Devices," or "TOSHIBA Semiconductor Reliability Handbook" etc..
- The TOSHIBA products listed in this document are intended for usage in general electronics applications (computer, personal equipment, office equipment, measuring equipment, industrial robotics, domestic appliances, etc.). These TOSHIBA products are neither intended nor warranted for usage in equipment that requires extraordinarily high quality and/or reliability or a malfunction or failure of which may cause loss of human life or bodily injury ("Unintended Usage"). Unintended Usage include atomic energy control instruments, airplane or spaceship instruments, transportation instruments, traffic signal instruments, combustion control instruments, medical instruments, all types of safety devices, etc.. Unintended Usage of TOSHIBA products listed in this document shall be made at the customer's own risk.
- The products described in this document are subject to the foreign exchange and foreign trade laws.
- The information contained herein is presented only as a guide for the applications of our products. No responsibility is assumed by TOSHIBA CORPORATION for any infringements of intellectual property or other rights of the third parties which may result from its use. No license is granted by implication or otherwise under any intellectual property or other rights of TOSHIBA CORPORATION or others.
- The information contained herein is subject to change without notice.