

## TS 950S, SD, SDX Roofing Filter Mod Installation Instructions.

The TS 950 roofing filter mod consists of a 6 pole, 4 to 5 kHz wide filter followed by a high dynamic range feedback amplifier. The amplifier provides enough gain to override the filter insertion loss.

The plot below shows the sweep frequency response of the front end and first IF filter installed in a TS 950SDX radio. The wider curve is the OEM response and the narrow curve is with the INRAD roofing filter mod added.

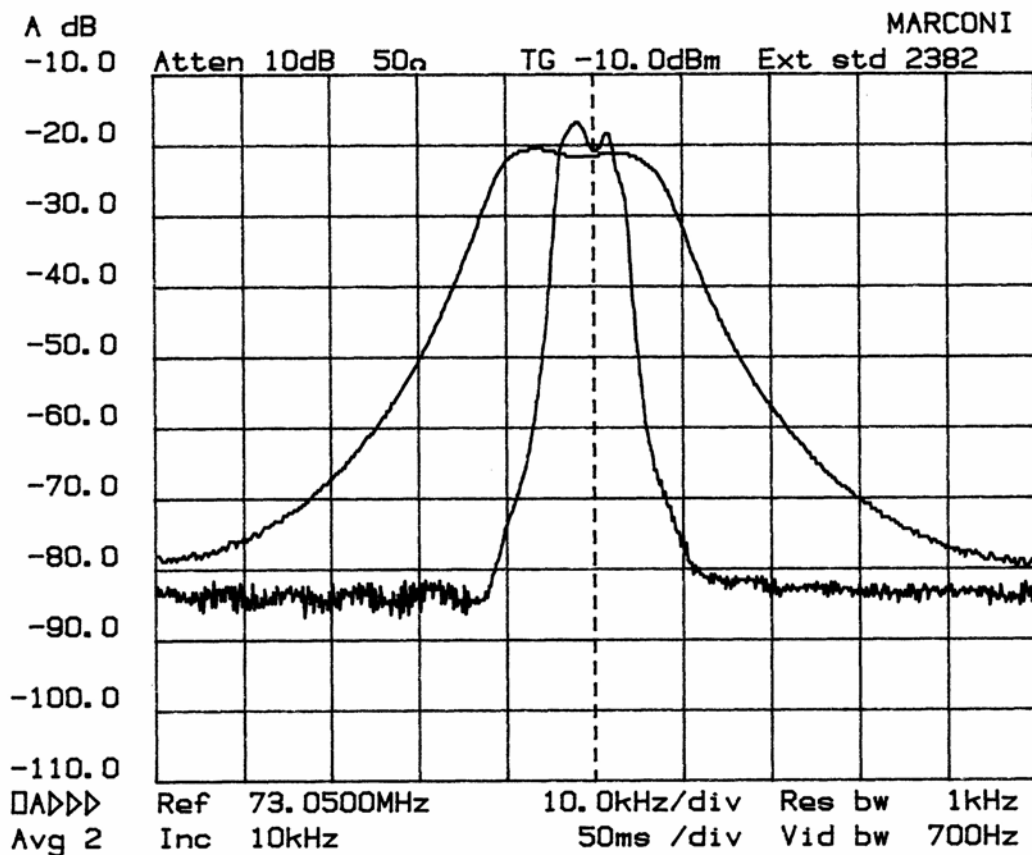

FIGURE 1

The result of the bandwidth improvement shown above is the reduction of close in intermodulation from multiple signals. The IMD dynamic range will be improved 5 to 15 dB for some signal spacings. Also, the blocking dynamic range will be improved up to 10 dB for close in signals.

## FREQUENTLY ASKED QUESTIONS

1. What can you expect from this mod?

Less IMD in crowded band conditions, particularly from stations at offset frequencies of 2 to 20 kHz on either side of the operating frequency.

2. Will it defeat the noise blanker?

No, the roofing filter is in the circuit before the noise blanker sample is taken. The filter delay is added to both signal and noise. Since less noise and fewer strong signals are able to reach the noise blanker, it actually improves its operation.

3. Will this mod allow for wide band SSB, AM and FM reception?

The overall widest bandwidth of the receiver will be determined by the roofing filter, which is about 5 kHz. AM and FM will be degraded, but not excessively. Normal 2400 Hz SSB will not be affected.

## DESCRIPTION OF OPERATION

The roofing filter mod inserts a narrow band crystal filter between the RF assembly and the IF board. An amplifier is included to compensate for the filter loss. Reducing the bandwidth at this point in the radio helps to keep strong off-frequency signals out of the second mixer, where they can cause intermodulation. Transmission is not affected, as the transmit signal does not pass through the roofing filter.

## INSTALLATION INSTRUCTIONS

***Warning: Modern radios contain components which may be damaged by static discharge (ESD). Precautions must be taken to eliminate any static electricity buildup between the operator and the radio before any of the internal circuits are touched. If you are not familiar with the proper techniques for this, consult the Radio Amateurs Handbook.***

Note: If you have a known test signal available before you start, note the S meter reading. After the installation, the S meter should read the approximately the same as before.

- \_\_1. Unplug the transceiver AC line cord from AC power.
- \_\_2. Place the radio upside down on a soft surface with the front panel facing you. Remove the bottom cover.
- \_\_3. Remove the INRAD roofing filter from its packing.
- \_\_4. Strip 1/8" from each end of the red and black wires.

- \_\_5. Solder the red wire to the pad marked +12V on the INRAD board.
- \_\_6. Solder the black wire to the pad marked GND.
- \_\_7. Insert the 2 mounting posts into the holes in the INRAD pc board. Insert one coax cable into J1 and the other into J2. Set aside.
- \_\_8. Locate the space between the signal board and the front panel that the mod will be mounted in. See figure 2.
- \_\_9. Lift the lock on the ribbon cable connector, CN1 and pull the cable end out.
- \_\_10. Lift the multicolored cable. Using the supplied solid wire, temporarily tie the cables out of the way.
- \_\_11. Before removing the nonstick papers from the mounting posts, put the mod in place as shown. Note that J2 should be to the left of CN1.
- \_\_12. When you are sure that you have found the correct position, remove the nonstick papers and insert the mod. Press the mounts in place.
- \_\_13. Position the red, black and two coax wires over the signal unit and through the opening in the shield to the IF unit. Use two tie wraps over the signal unit.
- \_\_14. Unplug the OEM coax from CN6 on the IF unit. Insert the coax from J2 on the mod into CN6.
- \_\_15. Insert the coax from CN6 into the double female coax adapter (supplied).
- \_\_16. Plug the coax from J1 on the mod into the other side of the double female coax adapter.
- \_\_17. Mount the solder lug under the gold screw in the corner of the signal unit, close to where the mod wires go through the chassis opening to the IF board. Use care not to short any traces with the lug.
- \_\_18. Double the black wire back and carefully solder to the lug.
- \_\_19. Locate L41 near CN5 on the IF board. Carefully solder the red wire onto the end of L41 closest to the front panel. This provides +15V.
- \_\_20. Place the ribbon cable back into connector CN1 and lock. Before pressing the lock down, make sure the cable is fully seated by rocking it carefully from side to side.
- \_\_21. Dress the wires neatly by tucking them into the metal slot between the IF UNIT and SIGNAL UNIT and carefully replace the bottom cover, making sure that none of the wires gets pinched. This completes the installation.

## **PARTS LIST**

**Assembled INRAD Roofing Filter board**

**2 Coax cables M-M**

**1 Coax adapter F-F**

**2 Board mounts**

**Red and black wire-15" each**

**1 Solder lug**

**1 piece of solid wire 6"**

**2 Tie wraps**

International Radio. © 2007 Modifications done at your own risk; seek help if you are not qualified. International Radio Corp. assumes no responsibility for any damages or injuries resulting from improper installation of this modification kit.

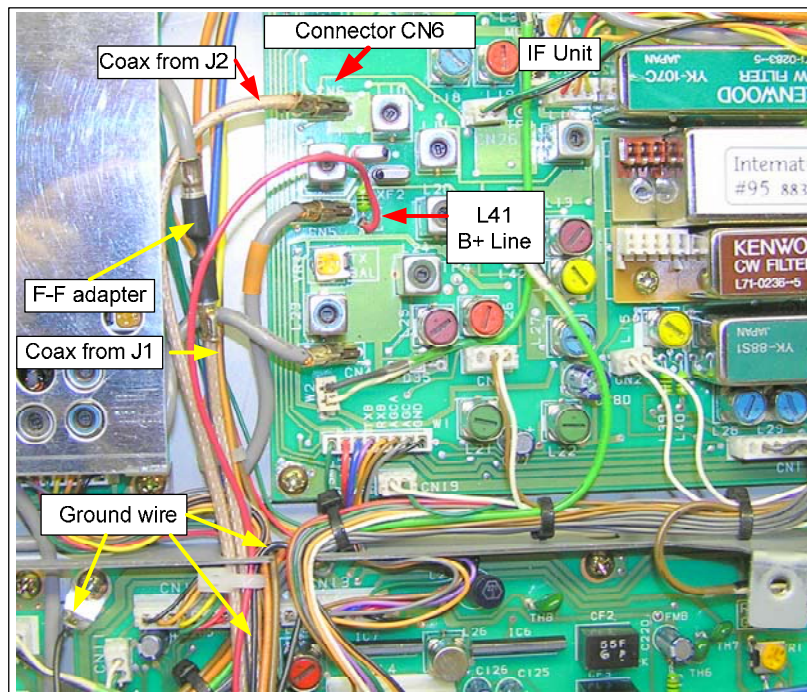
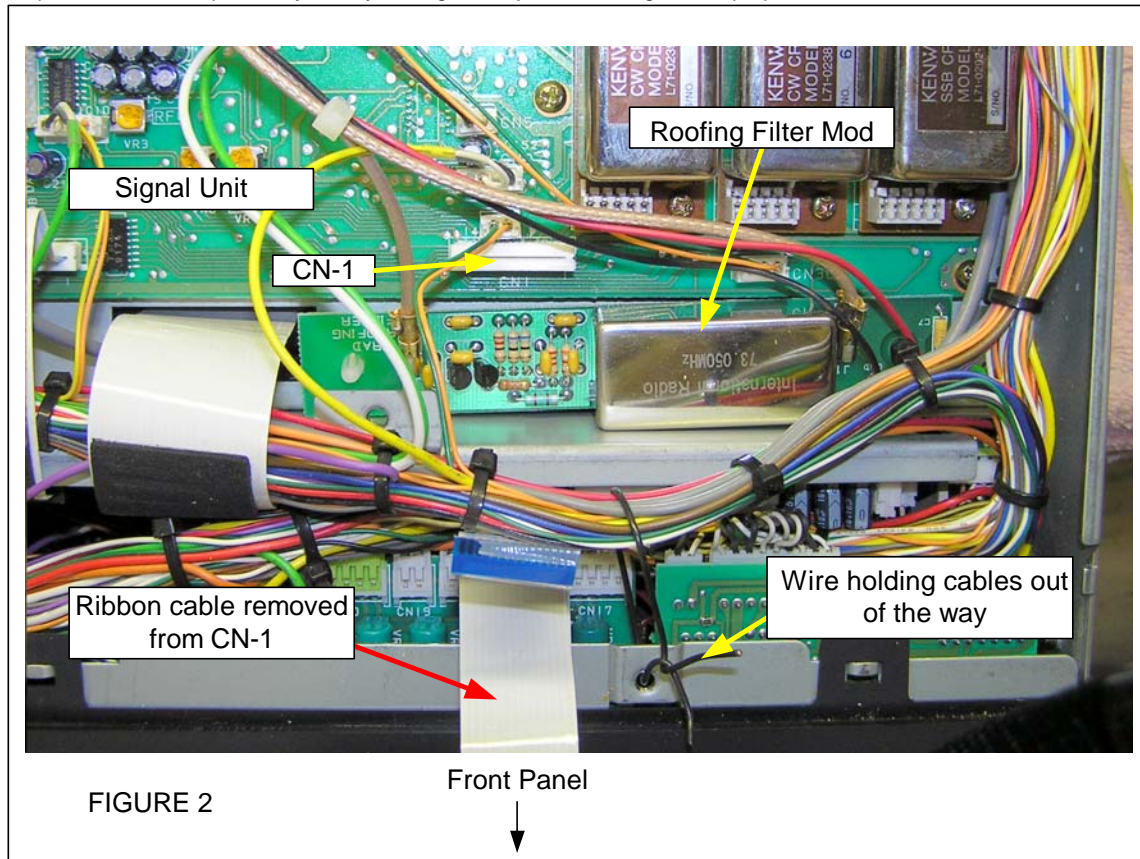

FIGURE 3

FIGURE 4

