

Genie Industries



Genie® Winches

Parts Manual

First Edition, First Printing
Part No. 35503



Genie® Winches

Genie Industries has endeavored to deliver the highest degree of accuracy possible. However, continuous improvement of our products is a Genie policy. Therefore product specifications are subject to change without notice.

Readers are encouraged to notify Genie of errors and send in suggestions for improvement. All communications will be carefully considered for future printings of this and other manuals. Please write or fax to the Technical Publications Team:

Genie Industries
PO Box 69
Redmond, WA 98073-0069, USA.

If you have any questions, call Genie Industries.

About This Manual

This Parts Manual is a historical summary of the various work winches used on Genie products over the years. Many of the parts listed are obsolete and unavailable from Genie Industries. This manual provides the reader with the information necessary to identify their work winch.

Genie® Industries

Copyright © 1995 by Genie Industries

First Edition: First Printing, May 1995

Genie® is a registered trademark
of Genie Industries. Registered 2009987

 Printed on recycled paper

Printed in U.S.A.

Table of Contents

How To Order Parts iv
Service Parts Fax Order Form v

Section One Single-handed Work Winches

Figure 1-A Fulton Model 935 1 - 2
Figure 1-B Dutton - Lainsen Model B 1200 1 - 4
Figure 1-C Fulton Model K1000 1 - 8
Figure 1-D Fulton Model K1050 1 - 10
Figure 1-E Fulton Model KX1051 1 - 14

Section Two Double-handed Work Winches

Figure 2-A Fulton Model 945 2 - 2
Figure 2-B Fulton Model K1500 2 - 6
Figure 2-C Fulton Model K1500 "Genie Modified" 2 - 10
Figure 2-D Fulton Model KX1550 2 - 14
Figure 2-E Fulton Model K1550 2 - 18

How To Order Parts

How to Order Service Parts

Please be prepared with the following information when ordering replacement parts for your Genie product:

- Machine model number
- Machine serial number
- Genie part number
- Part description and quantity
- Purchase order number
- "Ship to" address
- Desired method of shipment
- Name and telephone number of the authorized Genie Distributor in your area

If you don't know the name of your authorized distributor, or if your area is not currently serviced by an authorized distributor, call Genie.

Genie North America

Telephone (206) 881-1800
 Toll Free 800 536-1800 in U.S.A
 Toll Free 800 426-8089 in Canada
 Sales Fax (206) 883-3475
 Parts Fax (206) 556-8649

Genie Europe

Telephone (44) 01636-605030
 Fax (44) 01636-611090

Machine Information

Model

Serial Number

Product Code

Date of Purchase

Authorized Genie Distributor

Phone Number

Notes

Section One

Single-handled Work Winches

Figure 1-A

Fulton Model 935

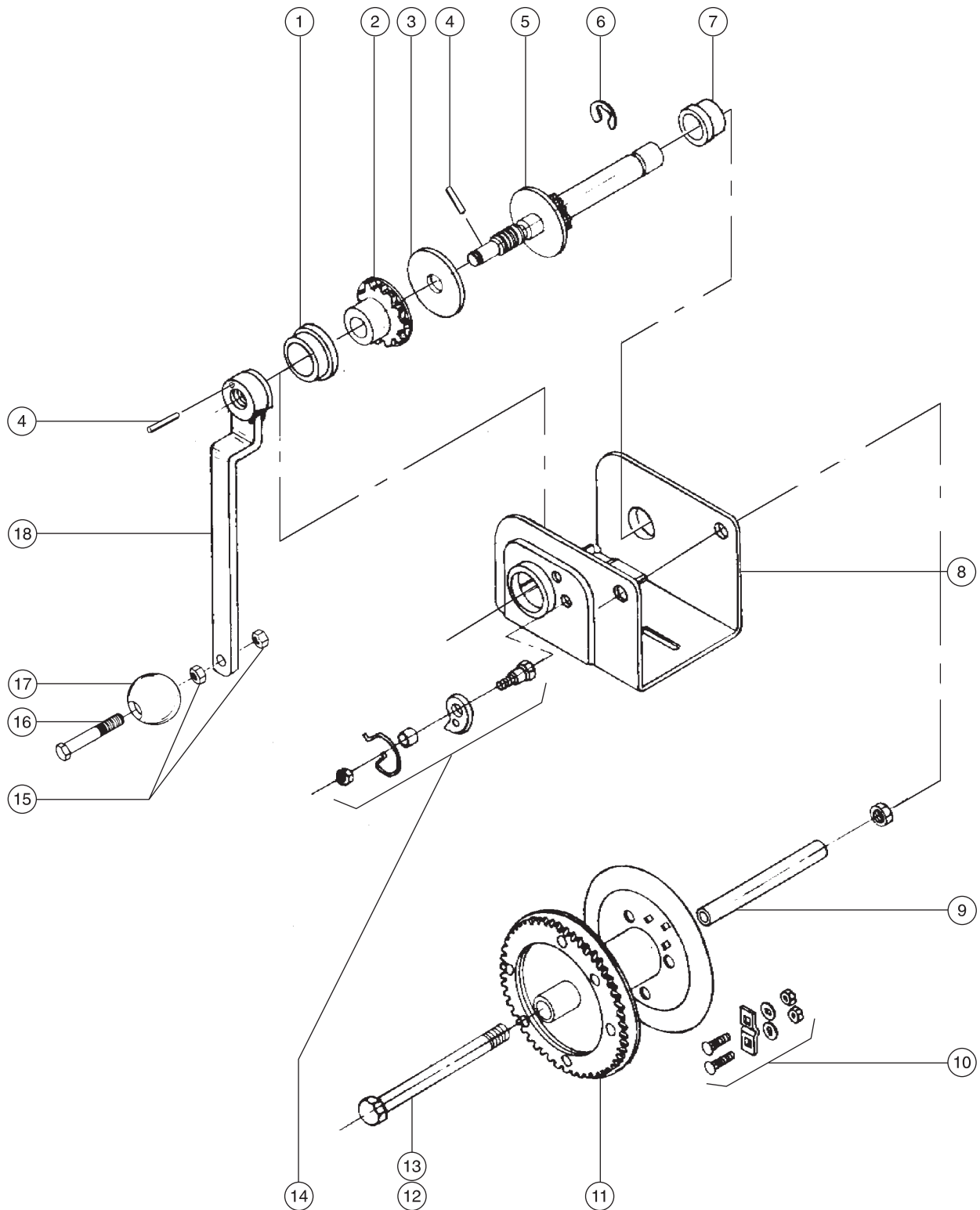

FIGURE 1-A

General Information

The Fulton 935 was used between 1973 and 1979. The stock 935 winch was modified by Genie to include two roll pins, one on the pinion shaft and the other on the control handle. Their relative position was 90° and were meant to prevent the loss of braking by restricting the counterclockwise

rotation of the winch handle. A ball knob was substituted for the stock rubber handle grip. The 935 had no gear cover, only one ratchet pawl and was painted gloss black. Applications included: Genie Lift and Mix-N-Match.

Parts List

Index	Part No.	Description	Quantity This Figure
1	6204	Large Bushing	1
2	5159	Ratchet Gear Assembly	1
3	5157	Brake Face	1
4	6608	Roll Pin, 0.188 x 0.75 inch	2
5	5158	Pinion Shaft Assembly	1
6	5315	Retaining Ring	1
7	6199	Small Bushing	1
8	5316	Frame Assembly	1
9	5320	Drum Spacer	1
10	6190	Cable Keeper Kit (includes mounting fasteners)	1
11	5321	Cable Drum Assembly	1
12	5317	Screw - HHC, 3/8 -16 x 4.5 inches	1
13	5319	Lock Nut, 3/8 -16	1
14	5156	Ratchet Kit	2
15	6022	Nut - Hex, 3/8 -16	2
16	6086	Screw, HHC, 3/8 -16 x 2.5 inches, GR 5	1
17	6082	Handle Ball Knob	1
18	5168	Handle Assembly (includes index numbers 4 and 15 through 17)	1

Figure 1-B

Dutton - Lainson Model B 1200

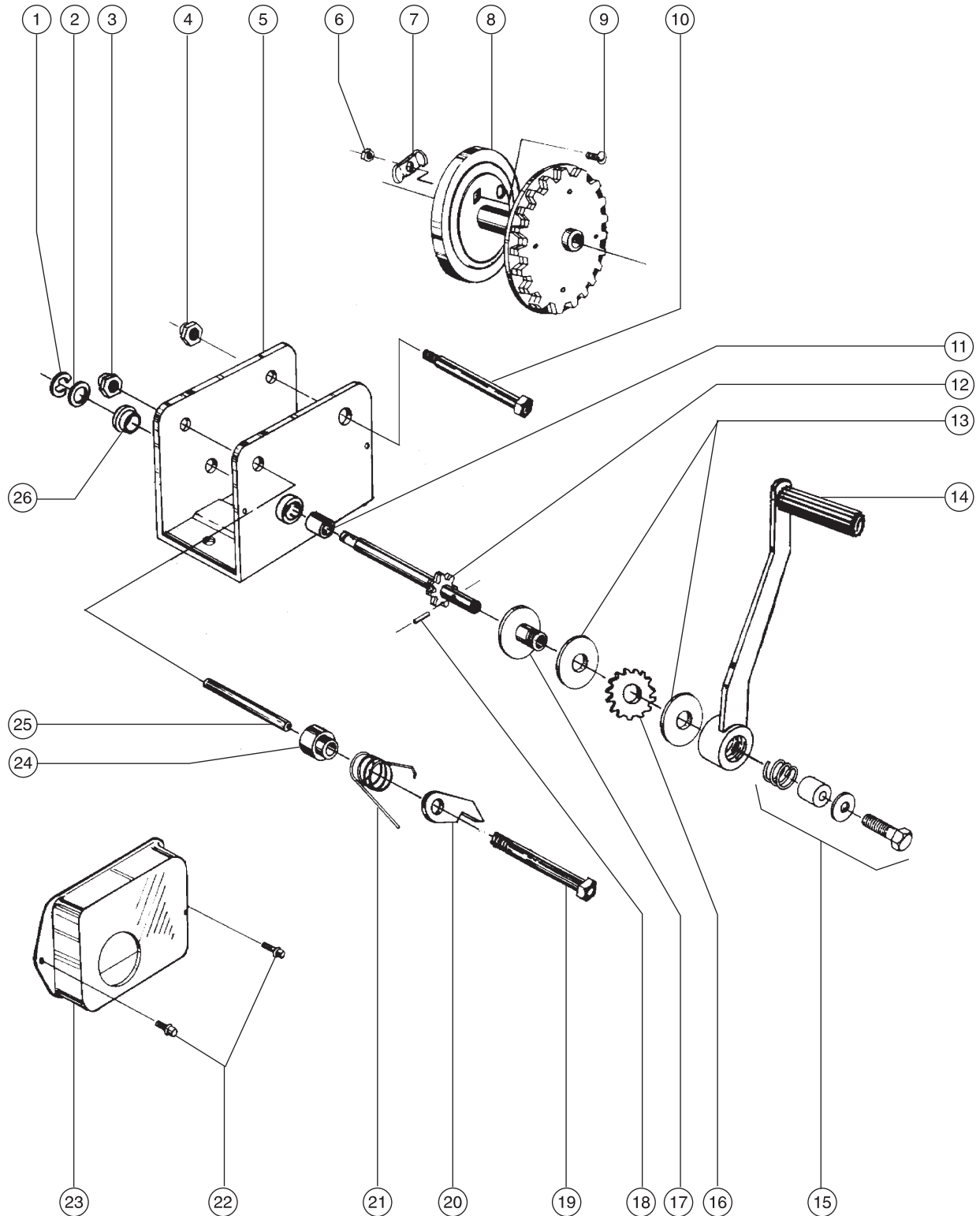

FIGURE 1-B

General Information

The Dutton - Lainson B 1200 was used between June 1979 and December 1979, but was soon dropped due to Dutton quality issues. The service period of this winch overlapped the Fulton 935 and K1000 winches. Applications included: Genie Lift.

Parts List

Index	Part No.	Description	Quantity This Figure
1	5341	Retaining Ring	1
2	5340	Spacer Washer	1
3	5337	Locknut, 3/8 inch	1
4	5342	Locknut, 7/16 inch	1
5	5322	Winch Frame	1
6	5335	Nut - Hex, 1/4 inch	1
7	5336	Rope Clamp	1
8	5358	Reel Assembly, 2.5 inch Hub	1
9	5334	Carriage Bolt	1
10	5325	Reel Bolt	1
11	5339	Needle Bearing, 9/16 inch	1
12	5357	Drive Shaft Assembly	1
13	5326	Plate - Brake Lining Pressure	2
14	5329	Winch Handle Assembly	1
15	5314	Brake Adapter Kit	1
16	5324	Ratchet Wheel	1
17	5327	Brake Winch Hub Assembly	1
18	5328	Roll Pin	1
19	5333	Ratchet Pawl Bolt	1
20	5332	Ratchet Pawl	1

This parts list continues. Please turn the page.

FIGURE 1-B

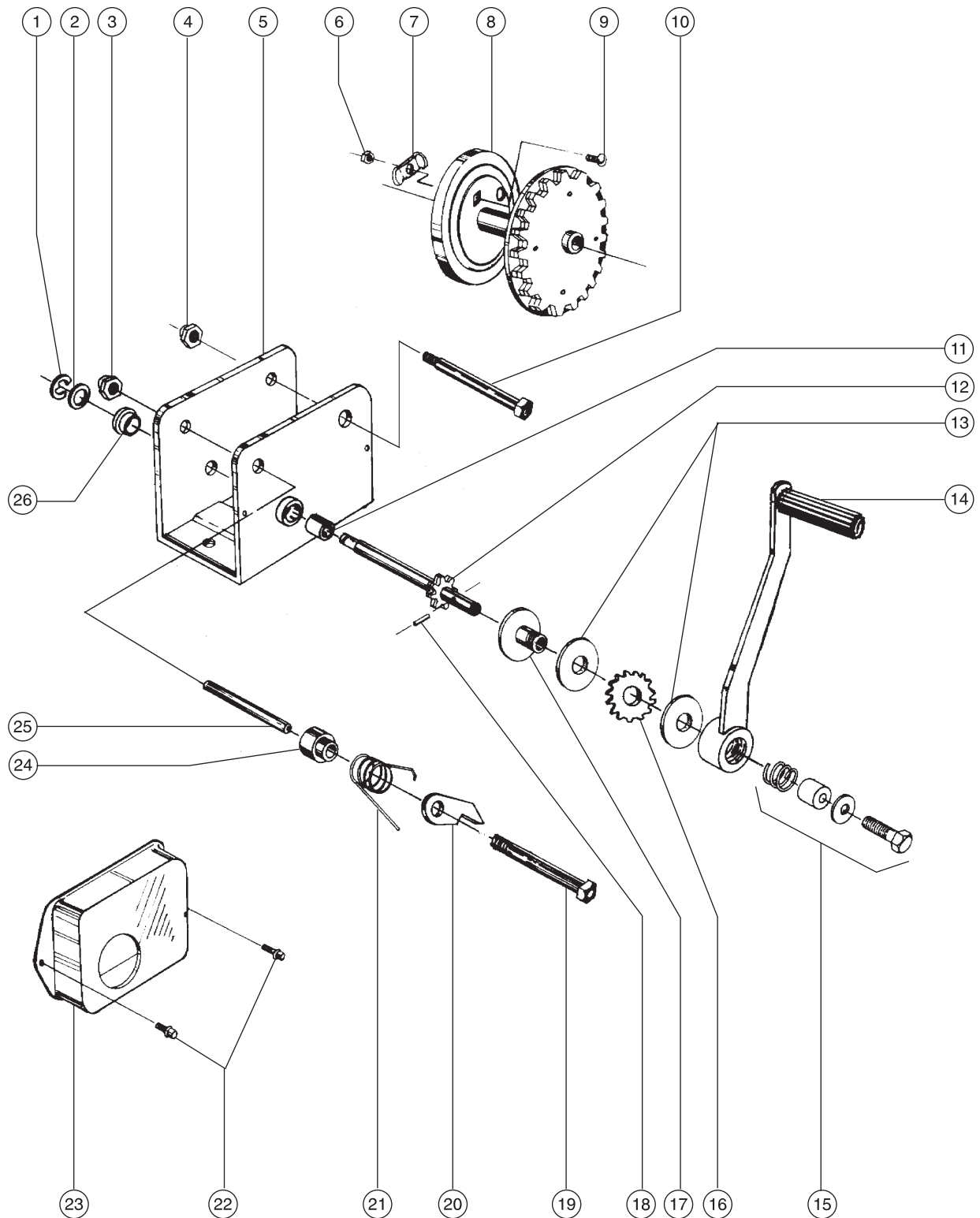

FIGURE 1-B

Index	Part No.	Description	Quantity This Figure
21	5331	Brake Ratchet Spring	1
22	5355	Self-tapping Screw	2
23	5356	Gear Cover	1
24	5330	Ratchet Pawl Spacer Bushing	1
25	5338	Spacer Sleeve	1
26	5323	Oilite Bearing	1

Figure 1-C

Fulton Model K1000

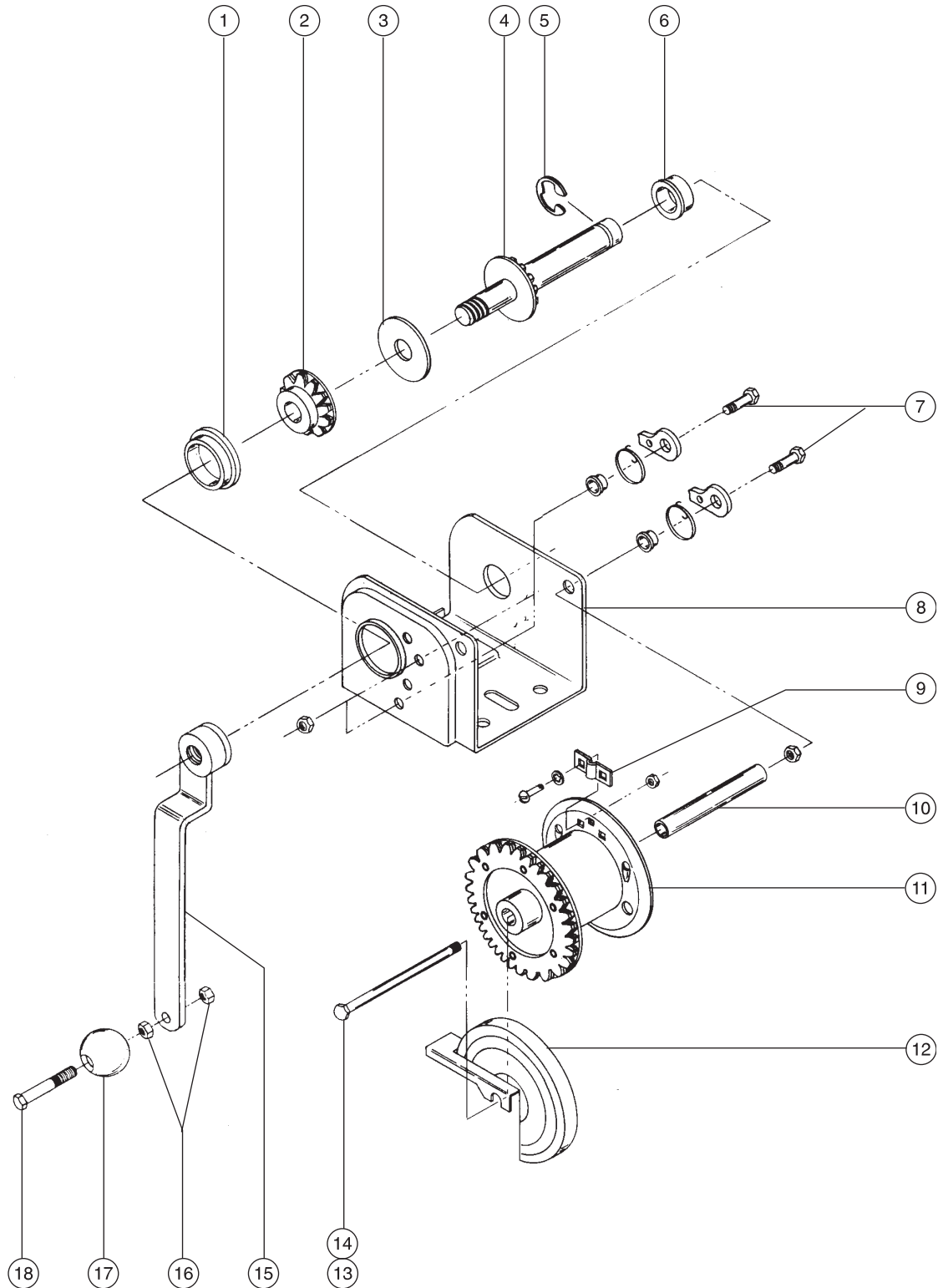

FIGURE 1-C

General Information

The Fulton K1000 was used between 1979 and 1985. The K1000 followed the 935 (and Dutton - Lainson B1200). Early production was painted gloss black and in 1981, Fulton began zinc plating the K1000. Distinctions from the 935 include: the addition of a gear cover and a second ratchet pawl. For the Genie Lift, we shortened the pinion shaft and replaced the stock rubber handle grip with a

ball knob. A thrust washer was welded to the threaded end of the handle at Genie also. Applications included: Genie Lift, Handy Lift and Mix-N-Match. The KH1000 was used on the Manual Easy-Up. A heat treatment specification was the only difference between the KH1000 and the K1000.

Parts List

Index	Part No.	Description	Quantity This Figure
1	6204	Large Bushing	1
2	5159	Ratchet Gear Assembly	1
3	5157	Brake Face	1
4	5158	Pinion Shaft Assembly	1
5	5315	Retaining Ring	1
6	6199	Small Bushing	1
7	5156	Ratchet Kit (includes mounting fasteners)	2
8	5316	Frame Assembly	1
9	6190	Cable Keeper Kit (includes mounting fasteners)	1
10	5320	Cable Drum Spacer	1
11	5321	Cable Drum Assembly	1
12	5376	Cable Drum Cover	1
13	5317	Screw, HHC, 3/8 -16 x 4.5 inches	1
14	5319	Lock Nut, 3/8 -16	1
15	5168	Handle Assembly (includes index numbers 16 through 18)	1
16	6022	Nut - Hex, 3/8 -16	2
17	6082	Handle Ball Knob	1
18	6086	Screw, HHC, 3/8 -16 x 2.5 inches, GR 5	1

Figure 1-D

Fulton Model K1050

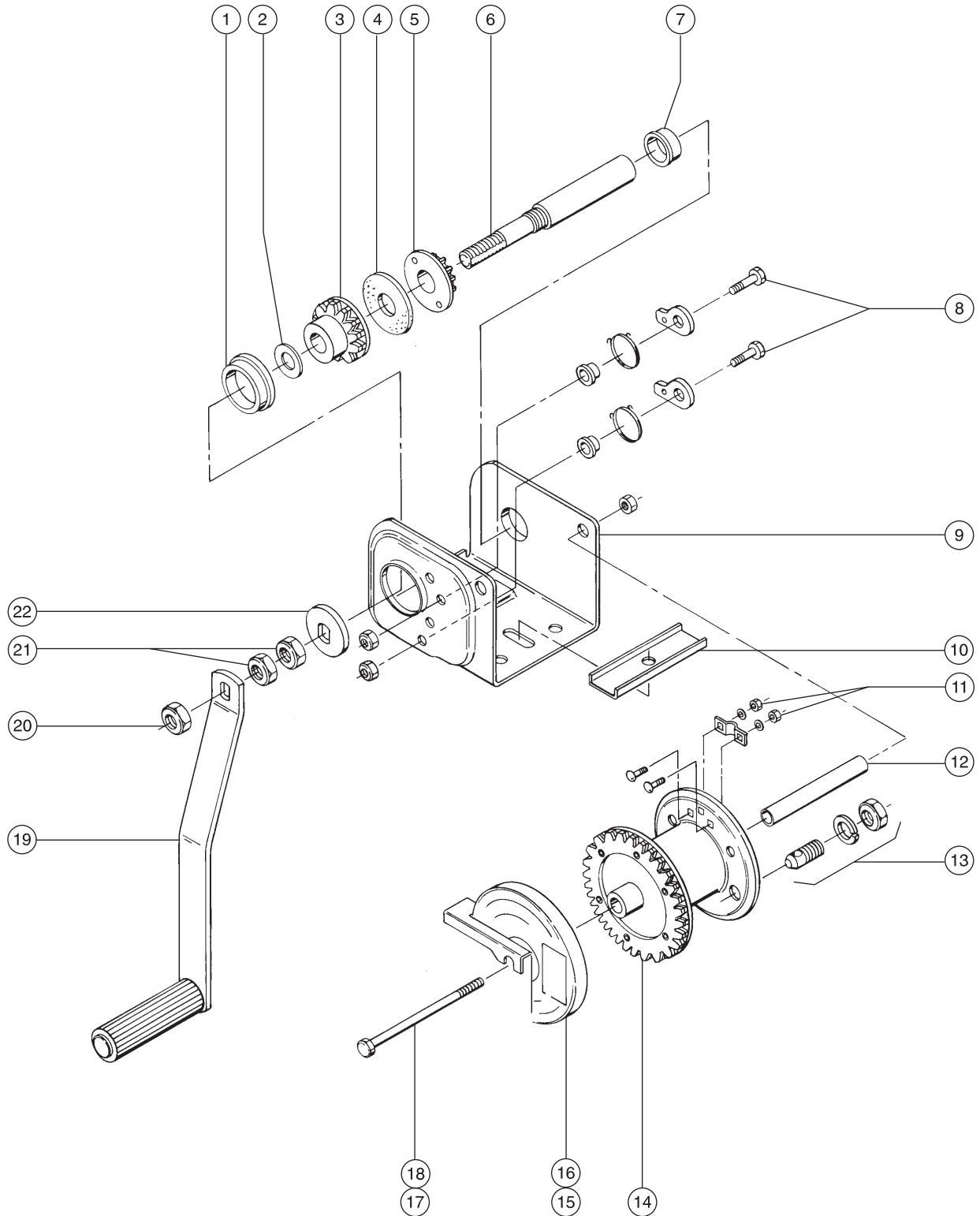

FIGURE 1-D

General Information

The Fulton K1050 was used between 1985 and 1986. The K1050 followed the K1000. Distinctions from the K1000 include: a threaded pinion gear nut and a longer pinion shaft to accommodate a new thrust washer and pinion plate. Fulton supplied

multiple handle lengths to suit our varied applications, each secured by jam and lock nuts. Applications included: Genie Lift, Handy Lift, Mix-N-Match and Manual Easy-Up.

Parts List

Index	Part No.	Description	Quantity This Figure
1	6204	Large Bushing	1
2	14190	Thrust Washer	1
3	14191	Ratchet Gear Assembly	1
4	5157	Friction Disk	1
5	14193	Pinion Gear Assembly	1
6	14194	Pinion Shaft	1
7	6199	Small Bushing	1
8	5156	Ratchet Pawl Kit (includes bolt, pawl, spring and nut)	2
9	Ref.	Winch Housing	—
10	15657P	Winch Reinforcement Plate	1
11	6190	Cable Keeper Kit (includes nut, lock washer, keeper clip and nut)	2
12	5320	Drum Spacer	1
13	9134	Cable Keeper Kit (threaded stud)	1
14	Ref.	Drum Assembly	—
15	5376	Drum Cover	1
16	5343	Decal, Maintain Lubrication	1
17	5317	Bolt, 3/8 -16 x 4.5 inches	1
18	5319	Locknut, 3/8 -16	1
19	16342	Handle, 12 inches (30.5 cm)	1
—	16344	Handle, 7.25 inches (18.4 cm)	—

This parts list continues. Please turn the page.

FIGURE 1-D

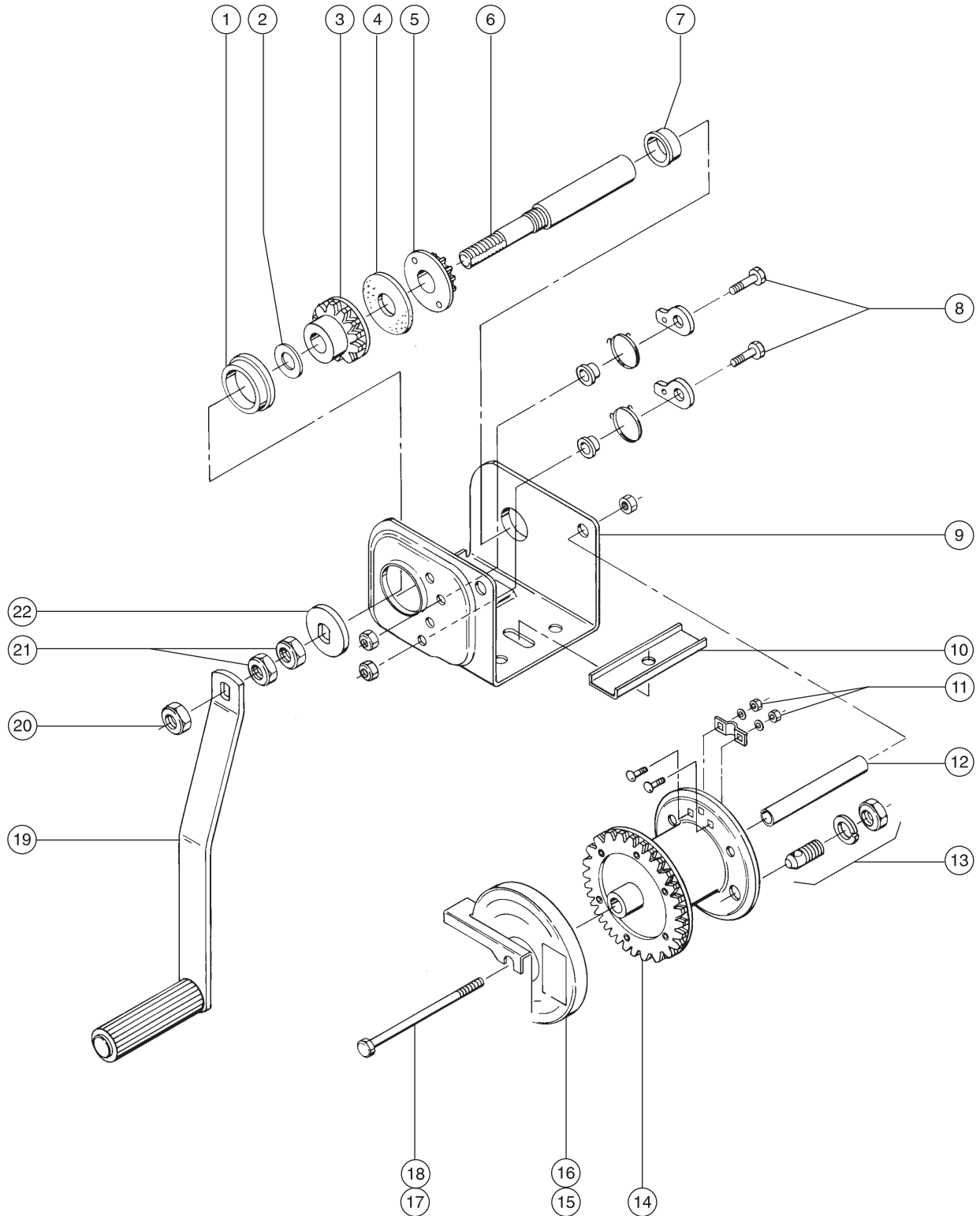

FIGURE 1-D

Index	Part No.	Description	Quantity This Figure
20	6086	Nut - Low Profile Nylock, 1/2 -13	1
21	6034	Nut - Hex Jam, 1/2 -13	2
22	14189	Pinion Plate	1

Figure 1-E

Fulton Model KX1051

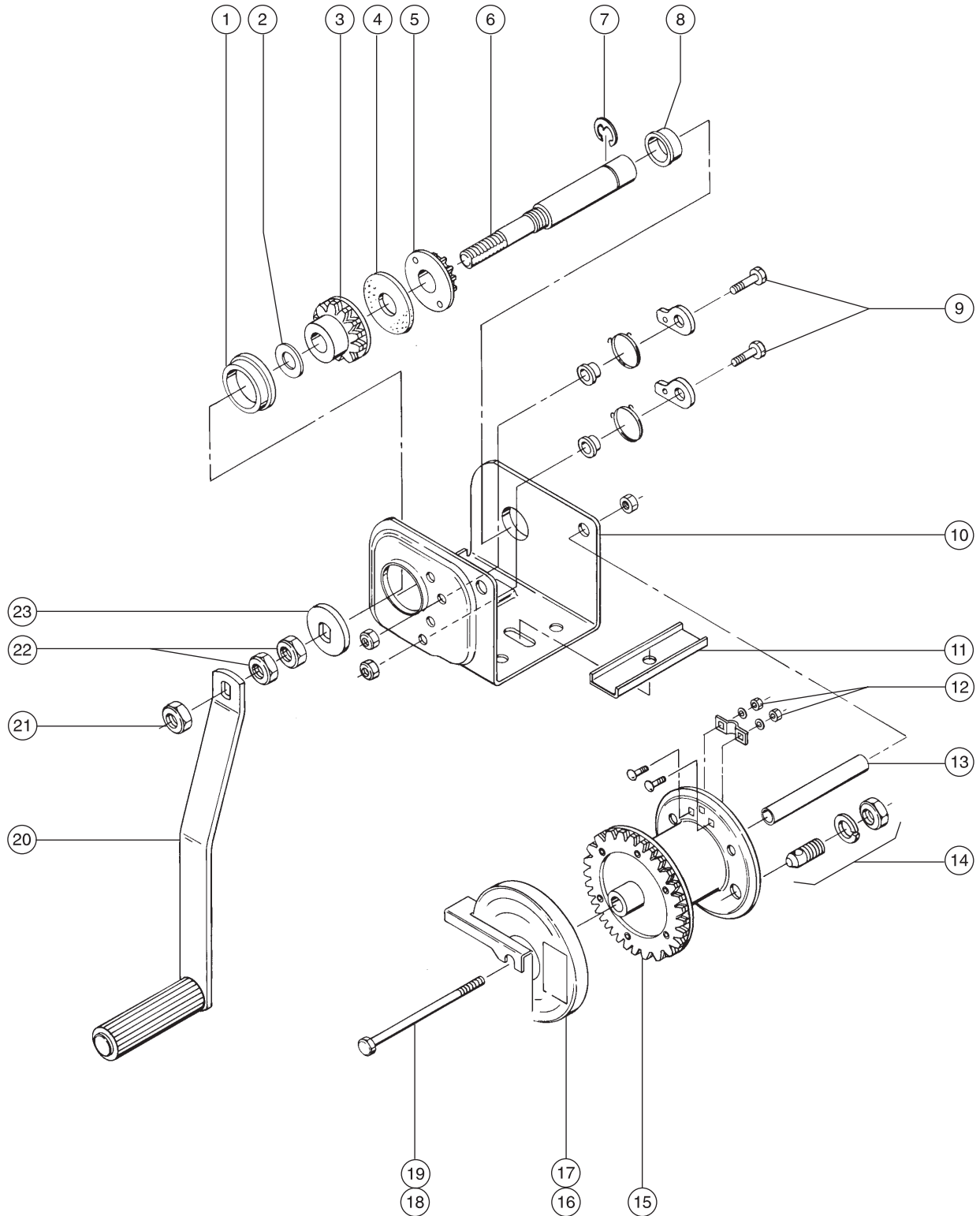

FIGURE 1-E

General Information

The Fulton K1051 was used from 1986 to present (April 1995). The K1051 followed the K1050. Distinctions from the K1050 include: the addition of an E-ring on the pinion shaft to limit it's side to side movement. The position of the lower ratchet pawl

was moved slightly upward to improve it's action. Fulton supplied multiple handle lengths to suit our varied applications, each secured by jam and lock nuts. Applications included: Genie Lift, Handy Lift, Mix-N-Match and Manual Easy-Up.

Parts List

Index	Part No.	Description	Quantity This Figure
1	6204	Large Bushing	1
2	14190	Thrust Washer	1
3	14191	Ratchet Gear Assembly	1
4	5157	Friction Disk	1
5	14193	Pinion Gear Assembly	1
6	14194	Pinion Shaft	1
7	6200	Retaining Ring	1
8	6199	Small Bushing	1
9	5156	Ratchet Pawl Kit (includes bolt, pawl, spring and nut)	2
10	Ref.	Winch Housing	—
11	15657P	Winch Reinforcement Plate	1
12	6190	Cable Keeper Kit (includes nut, lock washer, keeper clip and nut)	2
13	5320	Drum Spacer	1
14	9134	Cable Keeper Kit (threaded stud)	1
15	Ref.	Drum Assembly	—
16	5376	Drum Cover	1
17	5343	Decal, Maintain Lubrication	1
18	5317	Bolt, 3/8 -16 x 4.5 inches	1
19	5319	Locknut, 3/8 -16	1

This parts list continues. Please turn the page.

FIGURE 1-E

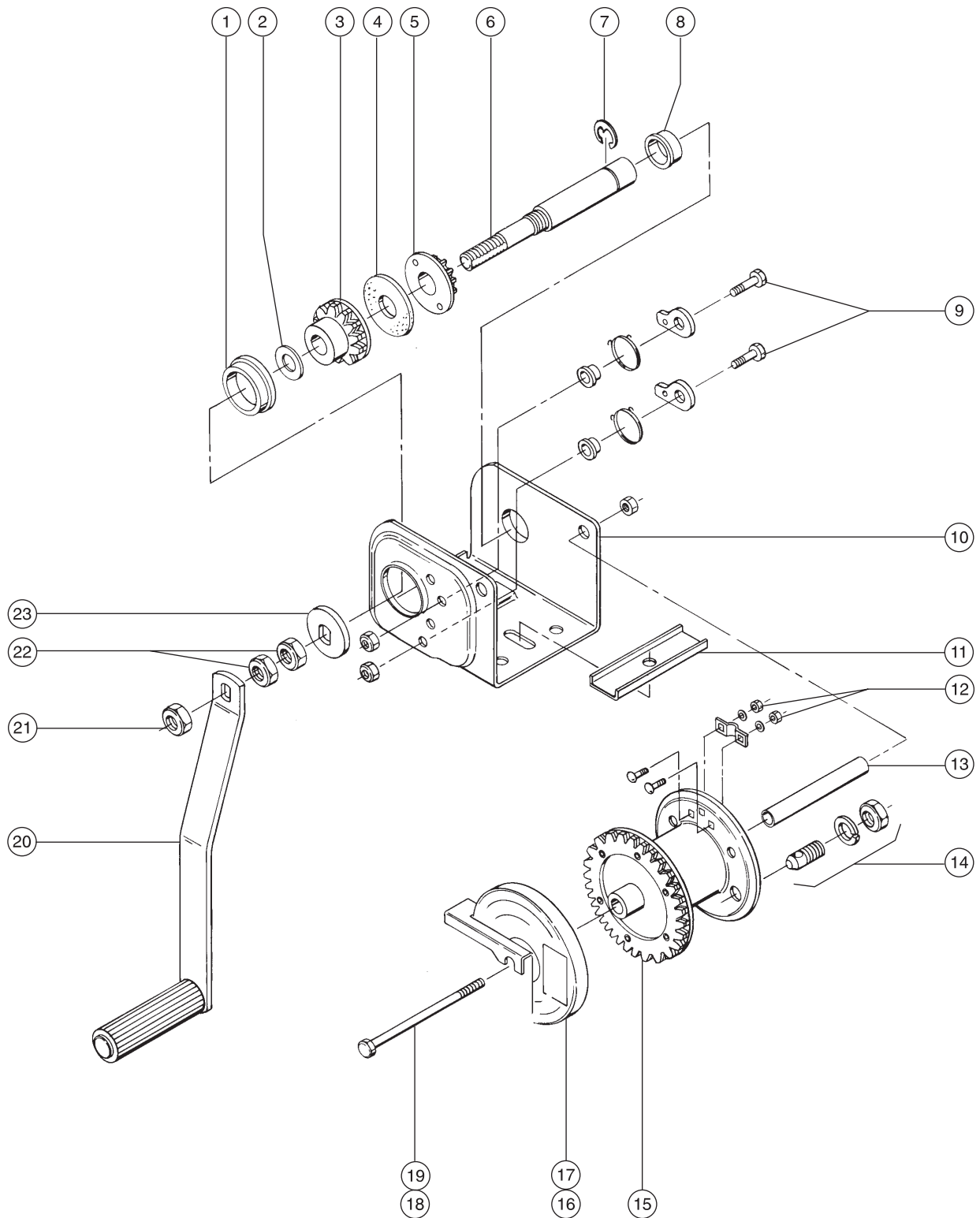

FIGURE 1-E

Index	Part No.	Description	Quantity This Figure
20	16342	Handle, 12 inches	1
—	16344	Handle, 7.25 inches	—
21	6086	Nut - Low Profile Nylock, 1/2 -13	1
22	6034	Nut - Hex Jam, 1/2 -13	2
23	14189	Pinion Plate	1

Notes

Section Two

Double-handled Work Winches

Figure 2-A

Fulton Model 945

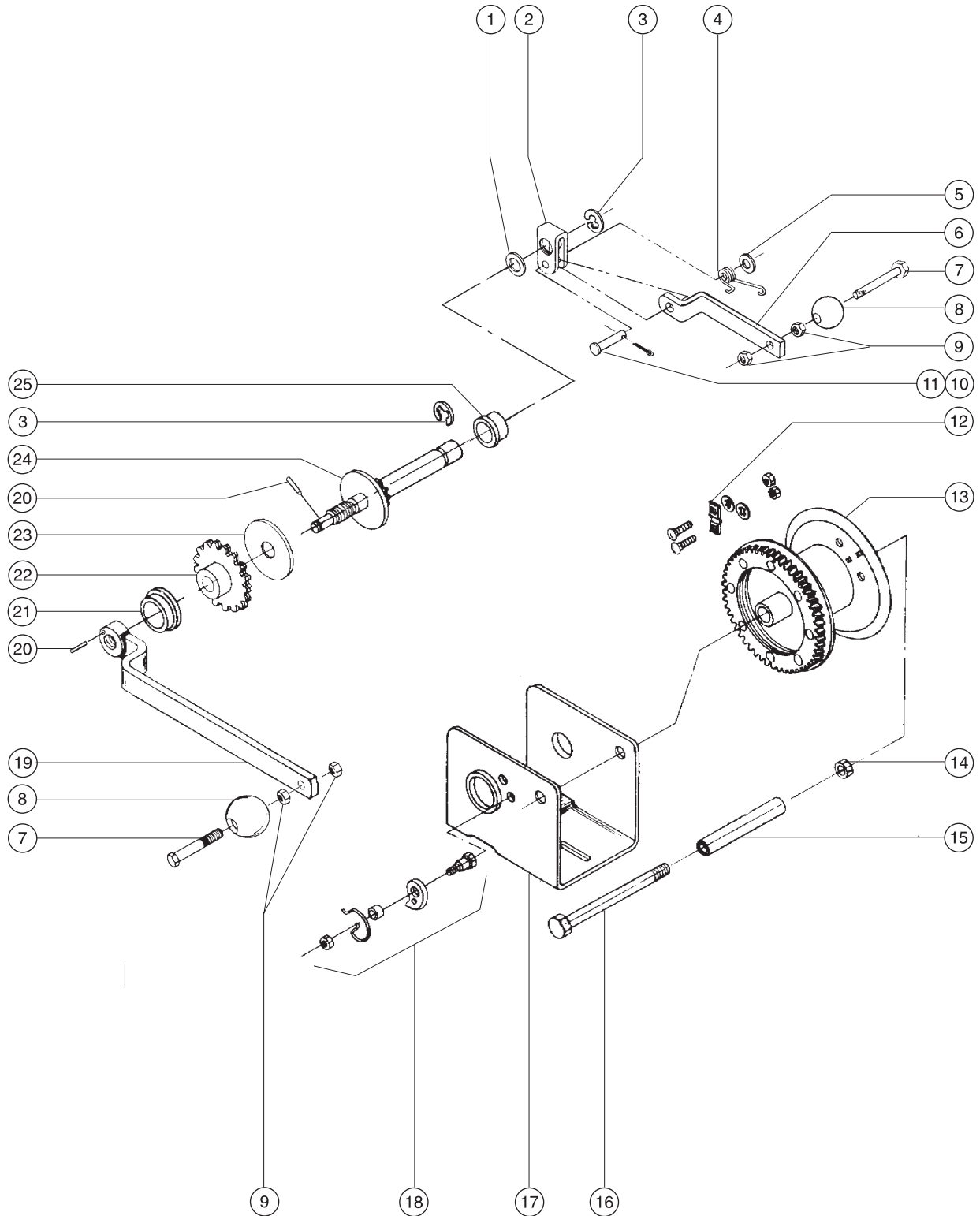

FIGURE 2-A

General Information

The Fulton 945 was used between 1976 and 1979. The stock 945 winch was modified by Genie to include two roll pins, one on the pinion shaft and the other on the control handle. Their relative position was 90° and were meant to prevent the loss of braking by restricting counterclockwise rotation of the control handle. Genie also replaced the stock rubber control handle grip with a ball

knob. At the opposite end of the pinion shaft was a Genie-designed, spring-loaded helper handle. This handle was designed to grip the pinion shaft when a load was being lifted and slip when a load was being lowered. The 945 was painted gloss black and had one brake face and one ratchet pawl. Applications included: Superlift, Super Tower, Super Man-Lift and Mix-N-Match.

Parts List

Index	Part No.	Description	Quantity	This Figure
1	6299	Spacer	1	1
2	6208	Crank Hinge	1	1
3	6200	Retaining Ring	2	2
4	6218	Spring	1	1
5	6097	Washer - Flat, 0.375 inch	1	1
6	6214	Helper Handle	1	1
7	6081	Screw - HHC, 3/8 -16 x 2.5 inches	2	2
8	6082	Ball - Handle Knob	2	2
9	6022	Nut - Hex, 3/8 -16	4	4
10	6284	Pin - Clevis	1	1
11	6265	Pin - Cotter	1	1
12	6190	Cable Keeper Kit (includes mounting fasteners)	1	1
13	Ref.	Cable Drum	1	1
14	6198	Nut - Lock, 1/2 -13	1	1
15	6184	Drum Bolt Spacer	1	1
16	6185	Screw - HHC, 1/2 -13 x 5.75 inches	1	1
17	Ref.	Winch Frame	1	1
18	6197	Ratchet Kit	1	1

This parts list continues. Please turn the page.

FIGURE 2-A

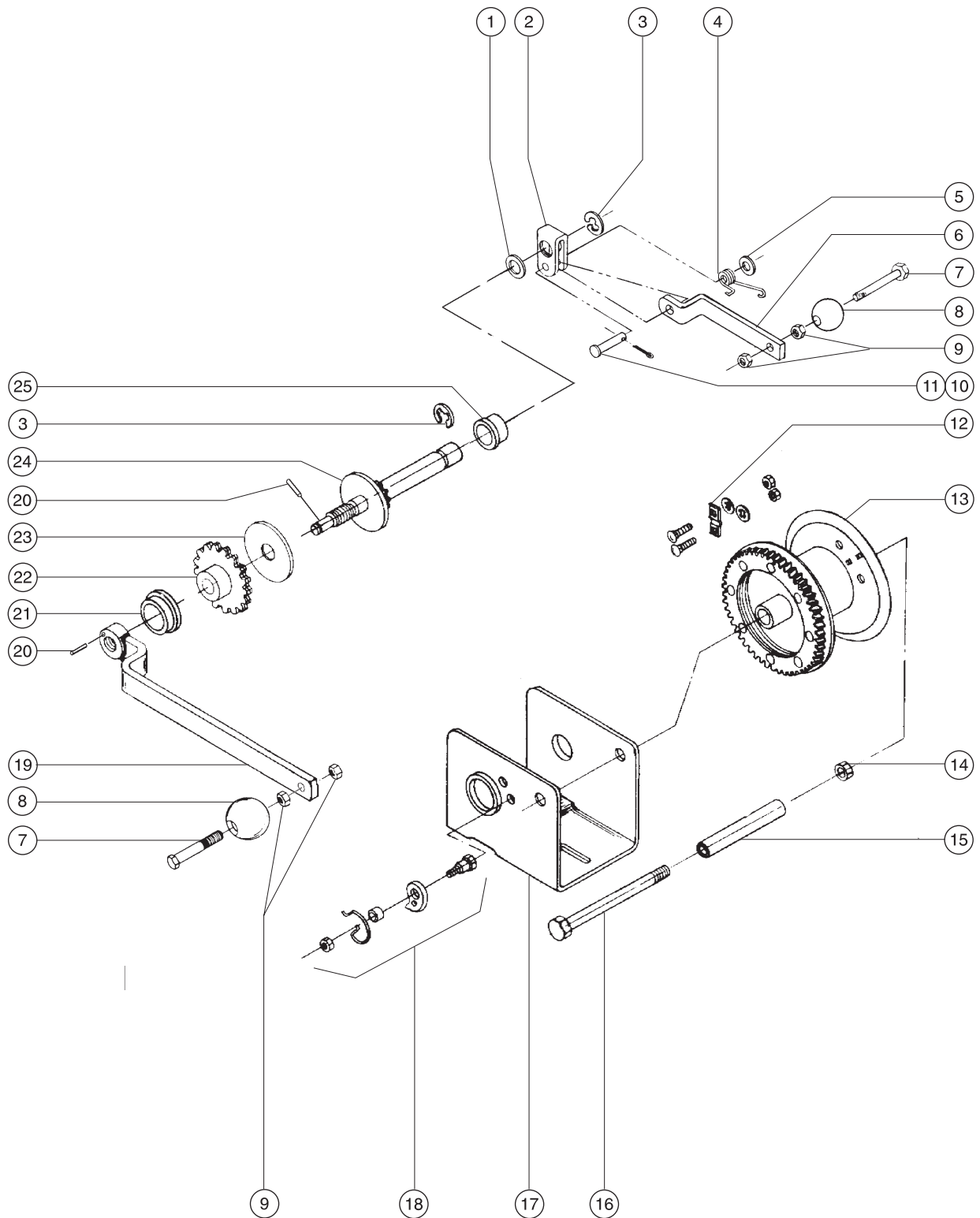

FIGURE 2-A

Index	Part No.	Description	Quantity This Figure
19	6779	Winch Handle	1
20	6608	Roll Pin, 0.188 x 0.75 inch	2
21	6204	Large Bushing	1
22	6777	Ratchet Gear	1
23	6202	Brake Face	1
24	6285	Pinion Shaft	1
25	6199	Small Bushing	1

Figure 2-B

Fulton Model K1500

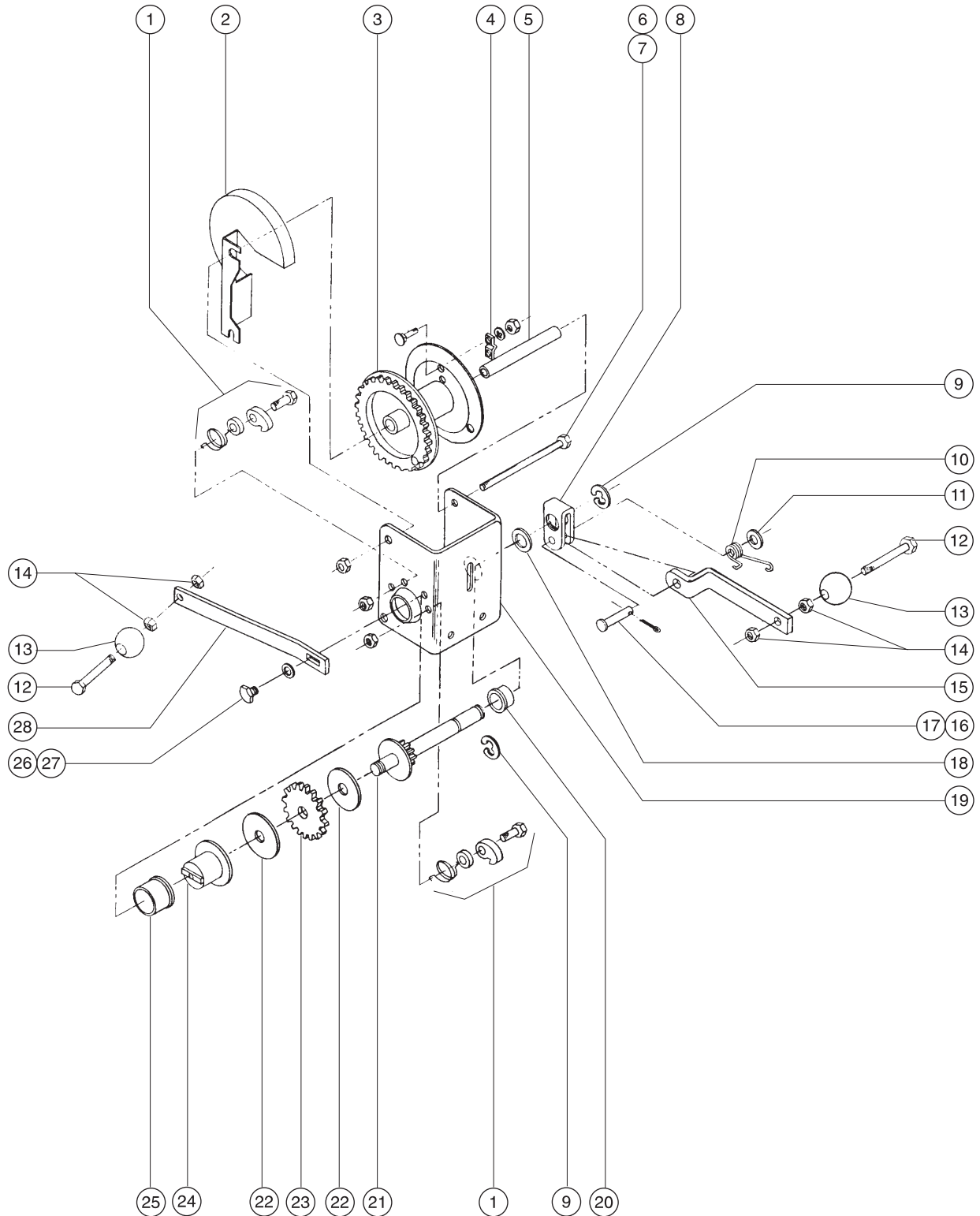

FIGURE 2-B

General Information

The Fulton K1500 was used between 1979 and 1982. The K1500 followed the 945. Early production was painted gloss black and in 1981, Fulton began zinc plating the K1500. Distinctions from the 945 model include a two-piece pinion shaft incorporating a threaded brake nut. A second brake face and ratchet pawl were also added.

Genie replaced the stock control handle grip with a ball knob. The K1500 also incorporated the Genie-designed, spring-loaded helper handle used on the 945 model. Applications included: Superlift, Super Tower, Super Man-Lift, Mix-N-Match, and later, the Manual Personnel Lift.

Parts List

Index	Part No.	Description	Quantity This Figure
1	6197	Ratchet Kit	2
2	6770	Gear Cover - Cable Drum	1
3	Ref.	Cable Drum	1
4	6190	Cable Keeper Kit (includes mounting fasteners)	1
5	6184	Spacer - Cable Drum Bolt	1
6	6185	Screw - HHC, 1/2 -13 x 5.75 inches	1
7	6198	Nut - Lock, 1/2 -13	1
8	6208	Crank Hinge	1
9	6200	Retaining Ring	2
10	6218	Spring	1
11	6097	Washer - Flat, 0.375 inch	1
12	6081	Screw - HHC, 3/8 -16 x 2.5 inches	2
13	6082	Ball - Handle Knob	2
14	6022	Nut - Hex, 3/8 -16	4
15	6214	Helper Handle	1
16	6284	Pin - Clevis	1
17	6265	Pin - Cotter	1
18	6299	Spacer	1

This parts list continues. Please turn the page.

FIGURE 2-B

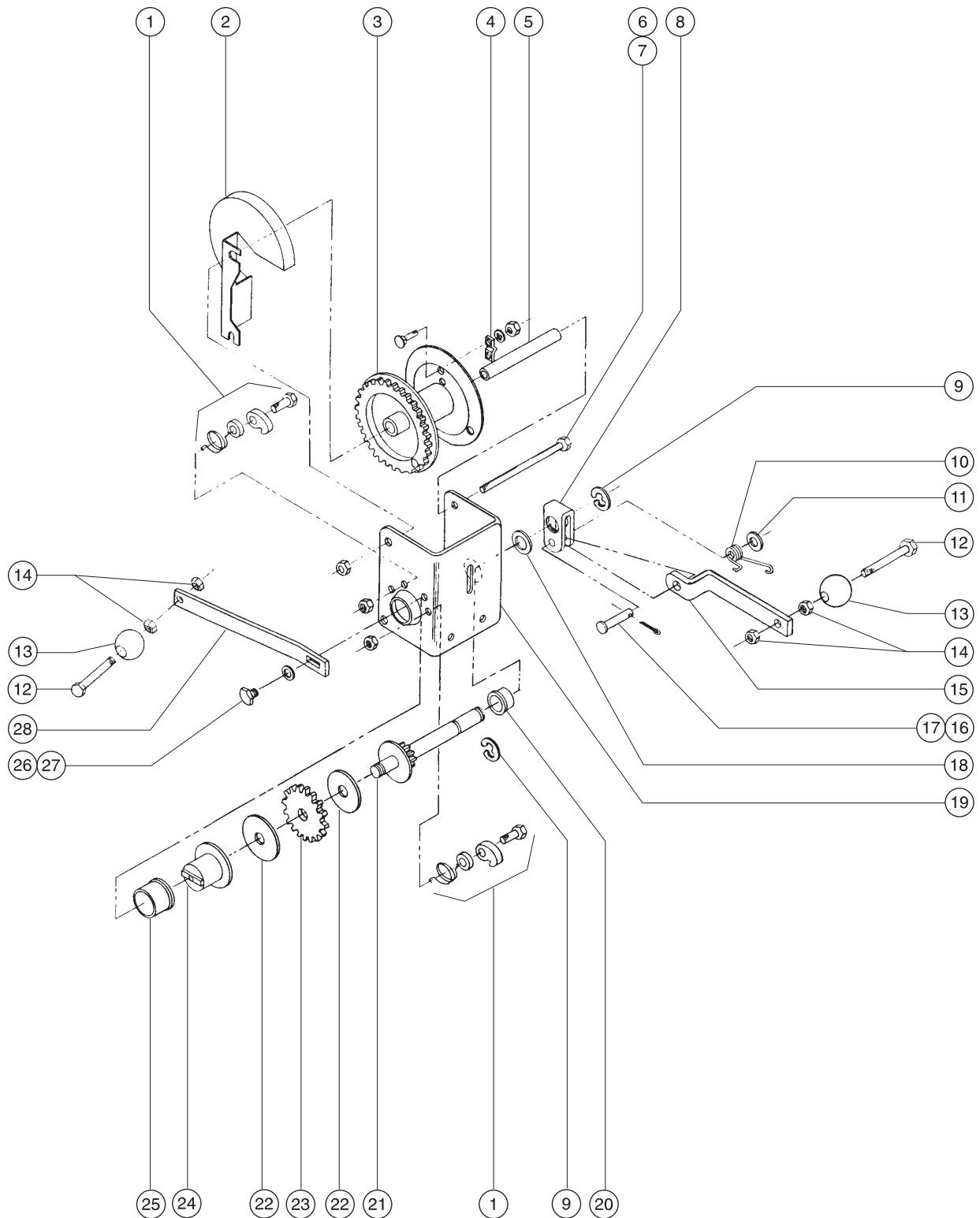

FIGURE 2-B

Index	Part No.	Description	Quantity This Figure
19	Ref.	Winch Frame	1
20	6199	Small Bushing	1
21	6285	Pinion Shaft	1
22	6202	Brake Face	2
23	6777	Ratchet Gear	1
24	6788	Brake Nut	1
25	6204	Large Bushing	1
26	6783	Screw - HHC, 1/4 -20 x 0.625 inch	1
27	6784	Washer - Flat, 1/4 inch	1
28	6779	Winch Handle	2

Figure 2-C

Fulton Model K1500 "Genie Modified"

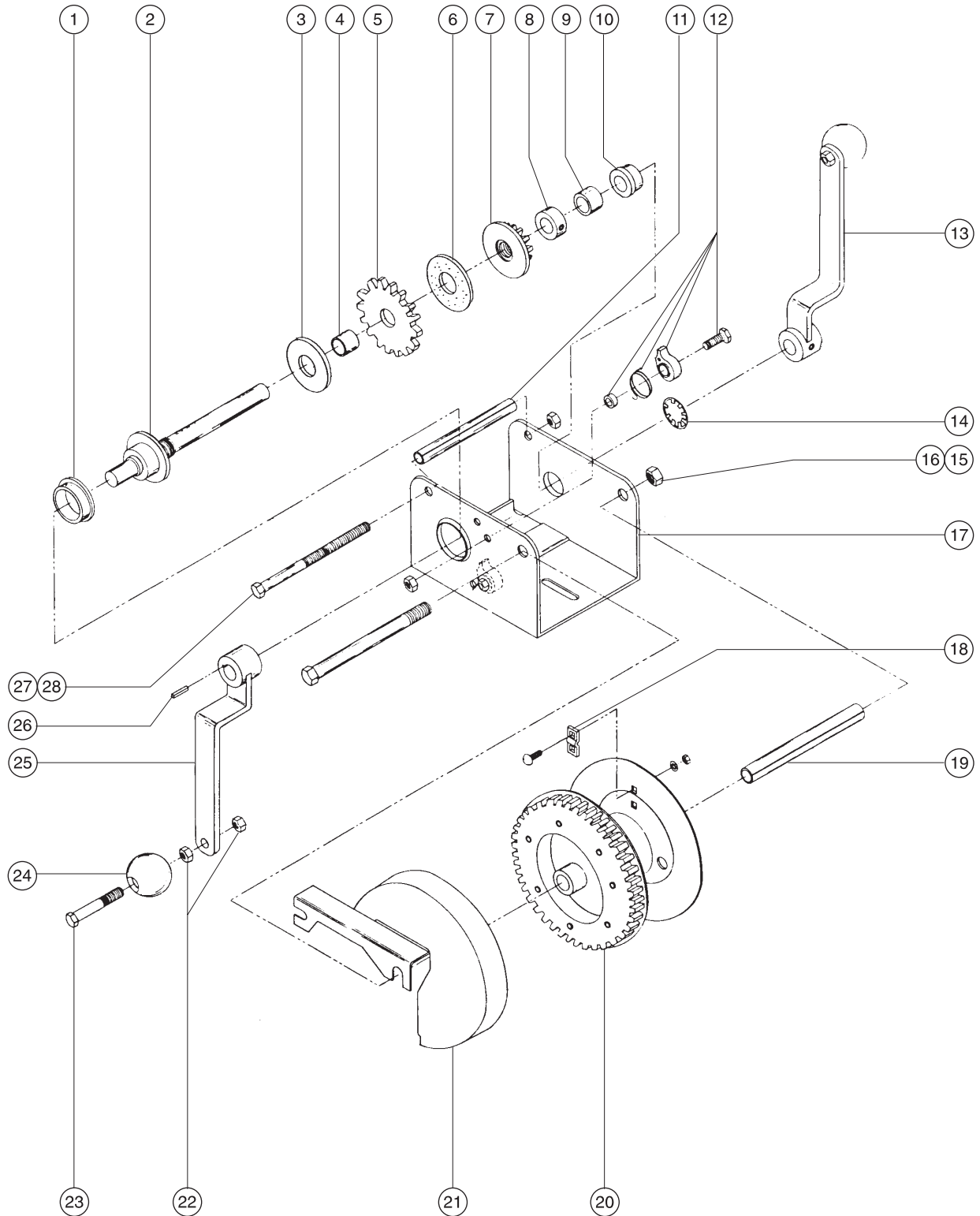

FIGURE 2-C

General Information

The Fulton K1500 “Genie Modified” was used between January 1982 and November 1982. This model followed the “unmodified” K1500. Genie modified the stock K1500 by removing and discarding the two-piece pinion shaft assembly. The brake face, ratchet gear and newly added Teflon spacer were saved and reworked to fit a

Genie-designed, one-piece pinion shaft. New Genie-designed crank handles eliminated the helper handle and were secured by a keystone and Allen screws. Applications included: Superlift, Super Tower, Super Man-Lift, Mix-N-Match and Manual Personnel Lift.

Parts List

Index	Part No.	Description	Quantity This Figure
1	6204	Bushing - Large	1
2	7556	Pinion Shaft Weldment	1
3	6150	Teflon Spacer	1
4	10010	Ratchet Gear Bushing	1
5	7549	Ratchet Gear	1
6	6151	Brake Disk	1
7	7559	Weldment - Pinion Gear	1
8	7579	Set Collar	1
9	7580	Nylon Spacer	1
10	7561	Bushing - Small	1
11	7584	Frame Spacer	1
12	6291	Ratchet Kit (includes mounting fasteners)	2
13	7581	Short Handle Assembly (includes index numbers 15-18)	—
—	7582	Long Handle Assembly (includes index numbers 15-18)	—
14	7575	Retaining Ring	1
15	6198	Nut - Lock, 1/2 -13	1
16	6185	Screw - HHC, 1/2 -13 x 5 3/4 inches	1
17	Ref.	Winch Housing	1

This parts list continues. Please turn the page.

FIGURE 2-C

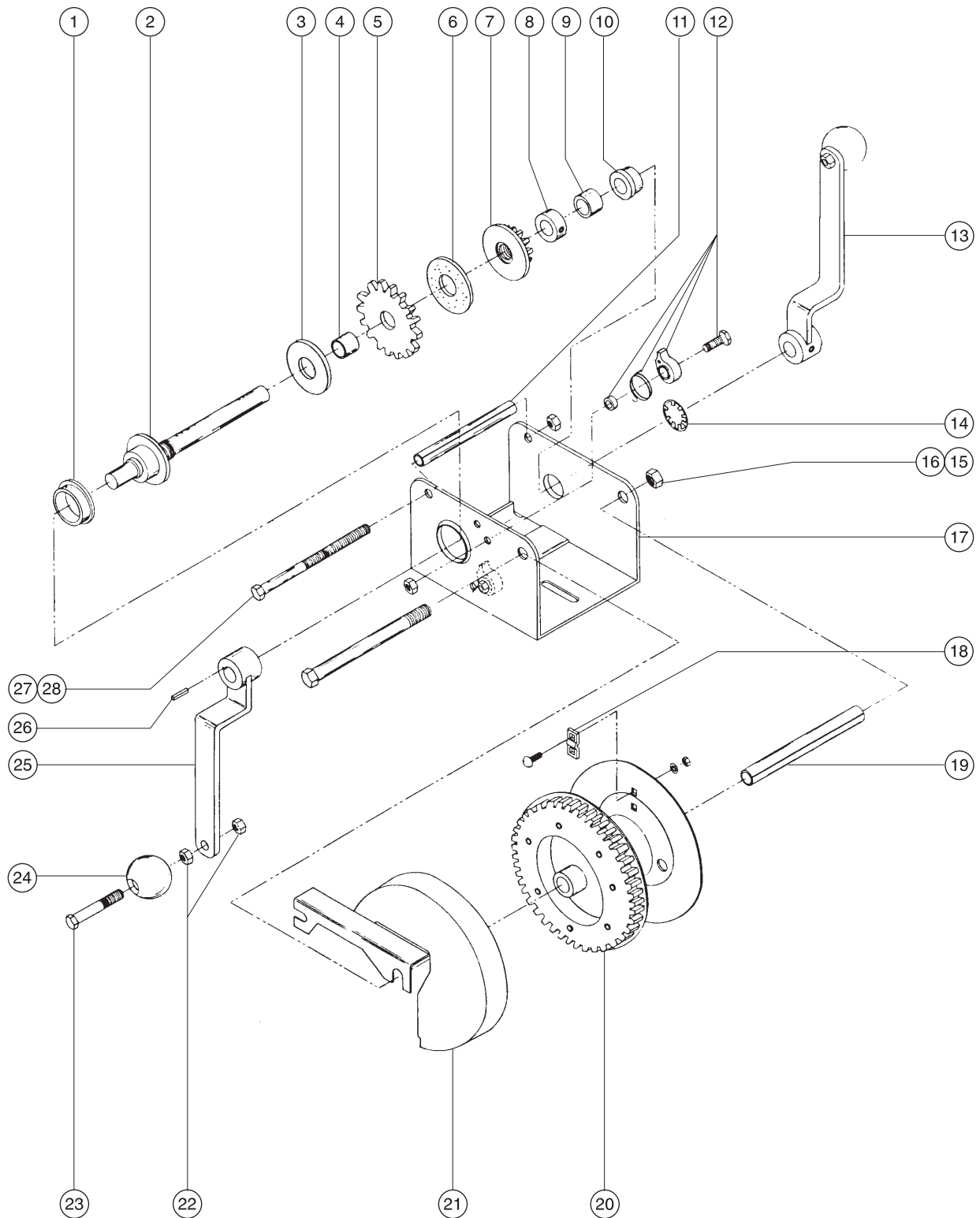

FIGURE 2-C

Index	Part No.	Description	Quantity This Figure
18	6190	Cable Keeper Kit (includes mounting fasteners)	1
19	6184	Drum Bolt Spacer	1
20	Ref.	Cable Drum Assembly	1
21	6770	Drum Gear Cover	1
22	6022	Nut - Hex, $\frac{3}{8}$ -16	4
23	8178	Screw - HHC, $\frac{3}{8}$ -16 x 2 $\frac{1}{2}$ inches	2
24	6082	Handle Ball Knob	2
25	7567	Weldment - Short Handle, 7.75 inches	2
—	7569	Weldment - Long Handle, 9 inches	2
26	7574	Handle Key, $\frac{1}{8}$ inch	2
27	7585	Screw - HHC, $\frac{3}{8}$ -16 x 5 $\frac{3}{4}$	1
28	4828	Nut - Lock, $\frac{3}{8}$ -16	1

Figure 2-D

Fulton KX1550

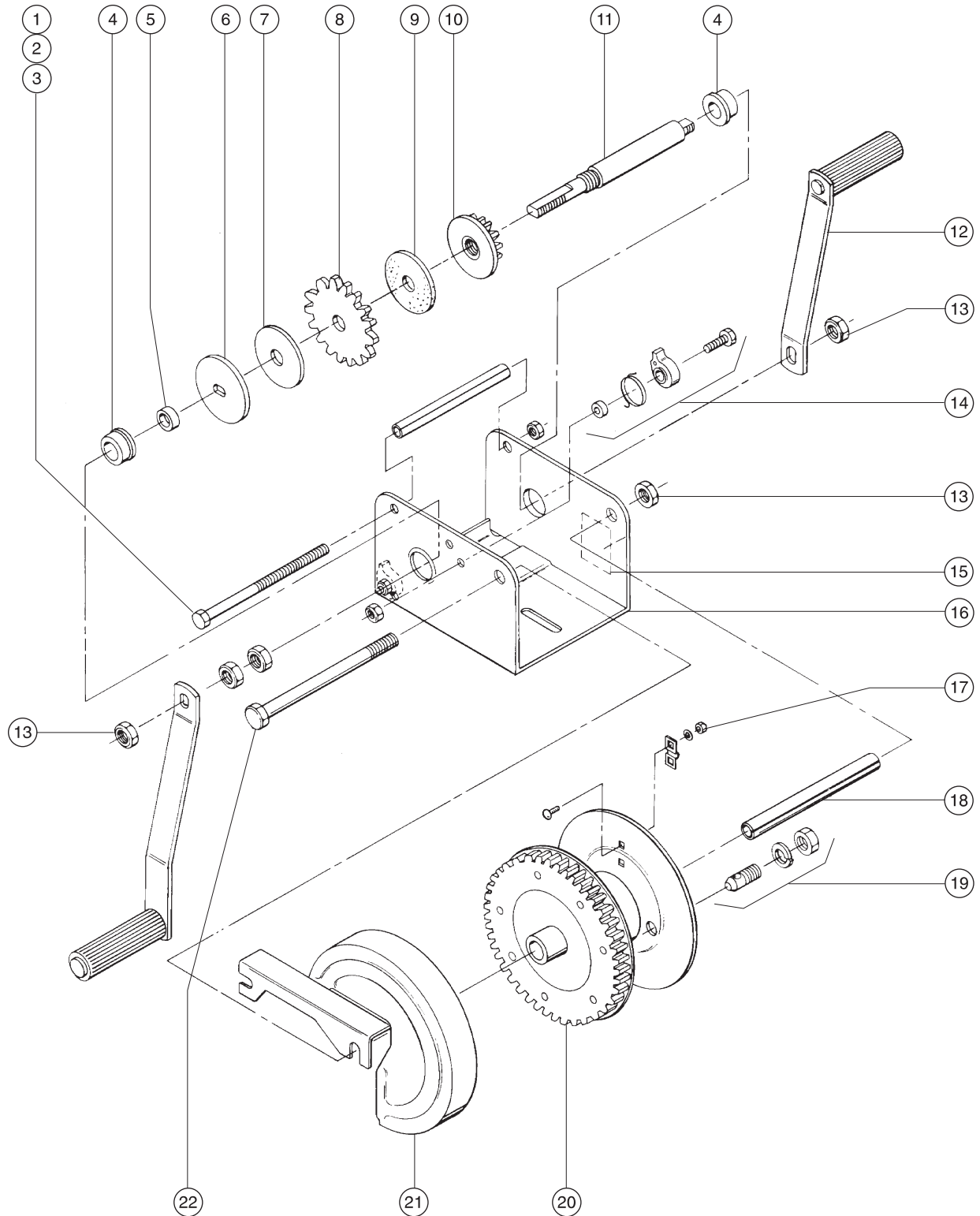

FIGURE 2-D

General Information

The Fulton KX1550 was used between November 1982 and October 1988. The KX1550 followed the K1500 "Genie Modified". It came from Fulton ready to use and included a redesigned pinion shaft assembly. The Teflon spacer was made tougher so it resisted compression better. Fulton supplied multiple handle lengths to suit our varied

applications. These applications included: Superlift, Super Tower, Mix-N-Match and Manual Personnel Lift (emergency lowering). The KH1550 was used in the Manual Personnel Lift platform. A heat treatment specification was the only difference between it and the KH1550 and the KX1550.

Parts List

Index	Part No.	Description	Quantity This Figure
—	7504	KX-1550 Winch Assembly, Short Handles	—
—	7505	KX-1550 Winch Assembly, Long Handles	—
—	7557	Pinion Replacement Kit (includes index numbers 4 - 13)	—
1	7256	Screw - HHC, 3/8 -16 x 5 3/4 inches	1
2	7584	Frame Spacer	1
3	5319	Nut - Lock, 3/8 -16.	1
4	6199	Pinion Bushing - Small, 0.75 x 0.5 inch	2
5	7598	Pinion Spacer, 1.25 x 0.5 x 0.875 inch	1
6	7591	Pinion Plate	1
7	7572	Teflon Spacer	1
8	6777	Ratchet Gear	1
9	7571	Brake Disk	1
10	7590	Pinion Gear	1
11	7588	Pinion Shaft	1
12	16344	Handle - Short, 7.25 inches (18.4 cm)	2
—	16343	Handle - Long, 8 inches (20.3 cm)	2
13	23415	Nut - Jam, 1/2 -13.....	4
14	6291	Ratchet Kit (includes mounting fasteners)	2
15	6787	Decal - Winch Lubrication Instructions	1
16	Ref.	Winch Housing	1

This parts list continues. Please turn the page.

FIGURE 2-D

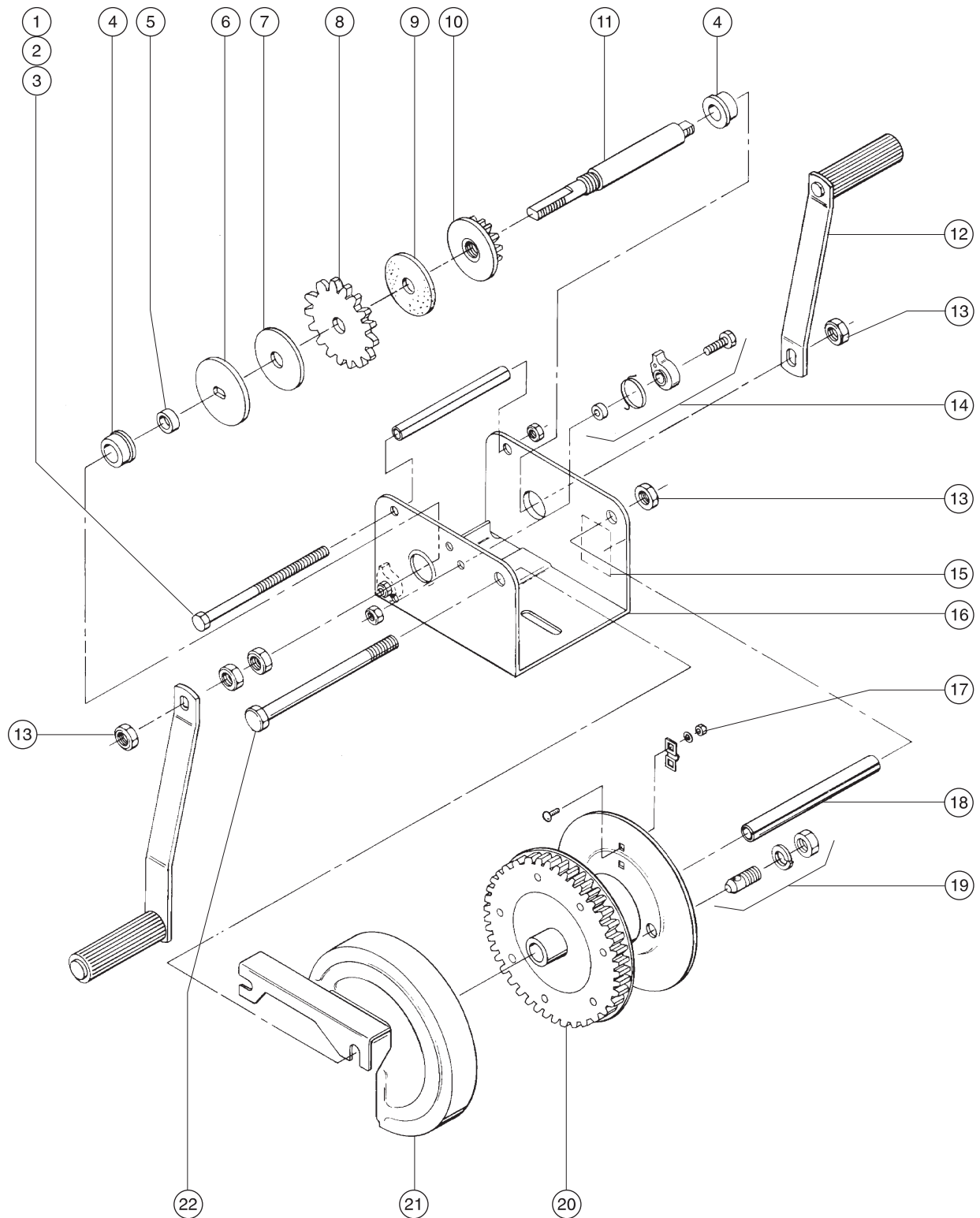
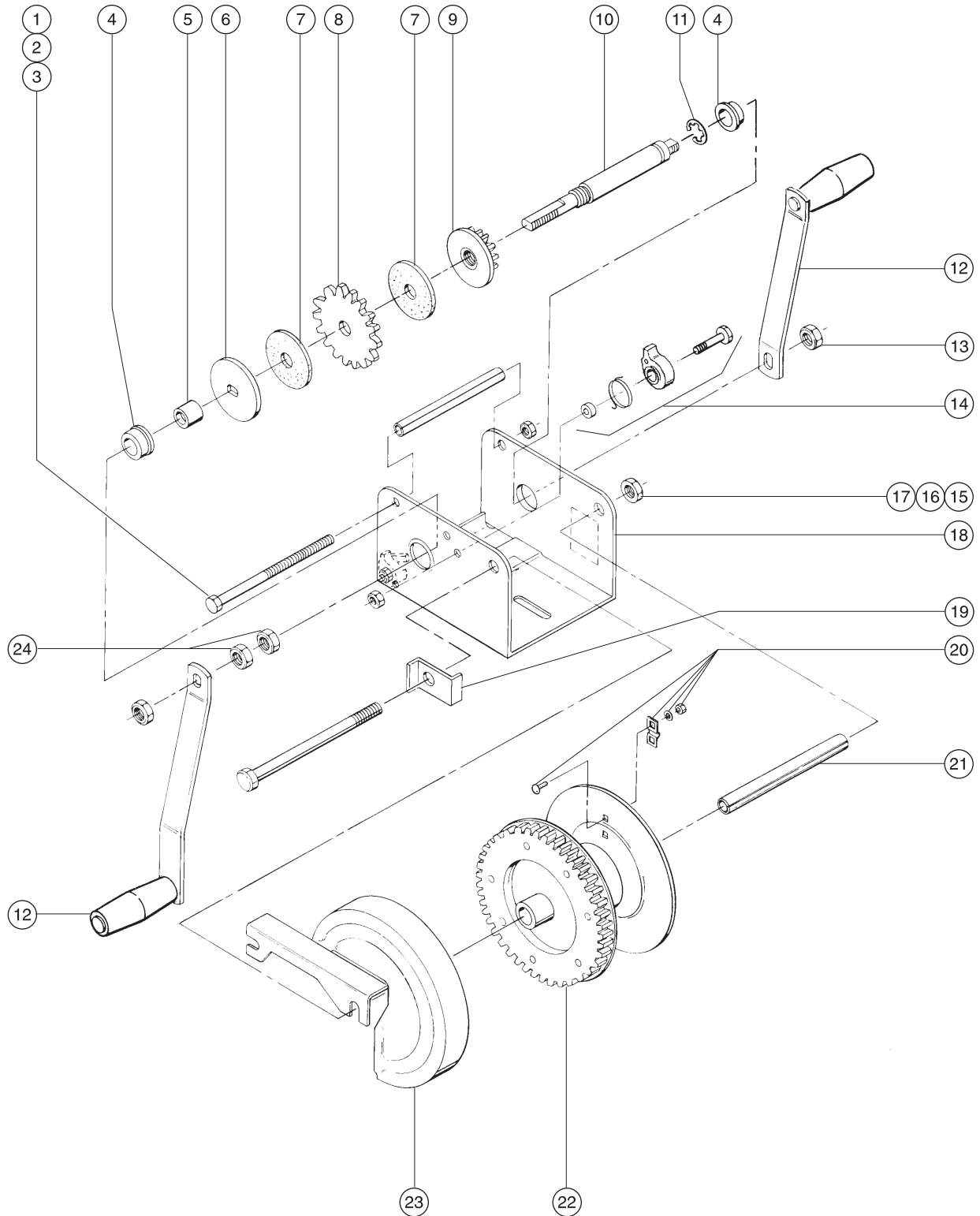

FIGURE 2-D

Index	Part No.	Description	Quantity This Figure
17	6190	Cable Keeper Kit (includes mounting fasteners)	1
18	6184	Drum Bolt Spacer	1
19	9134	Cable Keeper Kit (includes mounting fasteners)	1
20	Ref.	Cable Drum Assembly	1
21	6770	Gear Cover - Cable Drum	1
22	6185	Drum Bolt	1

Figure 2-E

Fulton Model K1550



General Information

The Fulton K1550 was used between October 1988 and June 1994. The K1550 followed the KX1550. Distinctions include the addition of an E-ring on the pinion shaft to limit it's side to side movement. In April 1989, the two ratchet pawls were "de-tuned" to reduce noise (this means that only one pawl struck the ratchet gear at a time). In December 1991, an anti-rotation tab was added

to prevent the drum bolt from turning with the drum. Applications included: Superlift, Super Tower, Mix-N-Match and Manual Personnel Lift (emergency lowering). The KH1550 was used on the Manual Personnel Lift platform and Manual Easy-Up. A heat treatment specification was the only difference between the KH1550 and the K1550.

Parts List

Index	Part No.	Description	Quantity	This Figure
—	32945	Single Speed Winch Assembly (handles not included)	—	—
1	7256	Screw - HHC, 5/16 -18 x 6 inches, GR5	1	1
2	7584	Spacer - Frame	1	1
3	5319	Nut - Lock, 5/16 -18	1	1
4	6199	Bushing - Pinion Shaft	2	2
5	32890	Spacer - Pinion Shaft.....	1	1
6	7591	Pinion Plate	1	1
7	7571	Friction Disk	2	2
8	6777	Ratchet Gear	1	1
9	7590	Pinion Gear	1	1
10	32891	Pinion Shaft	1	1
11	6200	Retaining Ring, 0.75 inches	1	1
12	33143	Handle, 6 inches (15.2 cm).....	2	2
—	33144	Handle, 8 inches (20.3 cm).....	2	2
13	6086	Nut - Low Profile Nylock, 1/2 -13	2	2
14	6291	Ratchet Kit	2	2
15	6086	Nut - Low Profile Lock, 1/2 -13	1	1
16	6184	Spacer - Drum	1	1
17	6185	Drum Bolt	1	1

This parts list continues. Please turn the page.

FIGURE 2-E

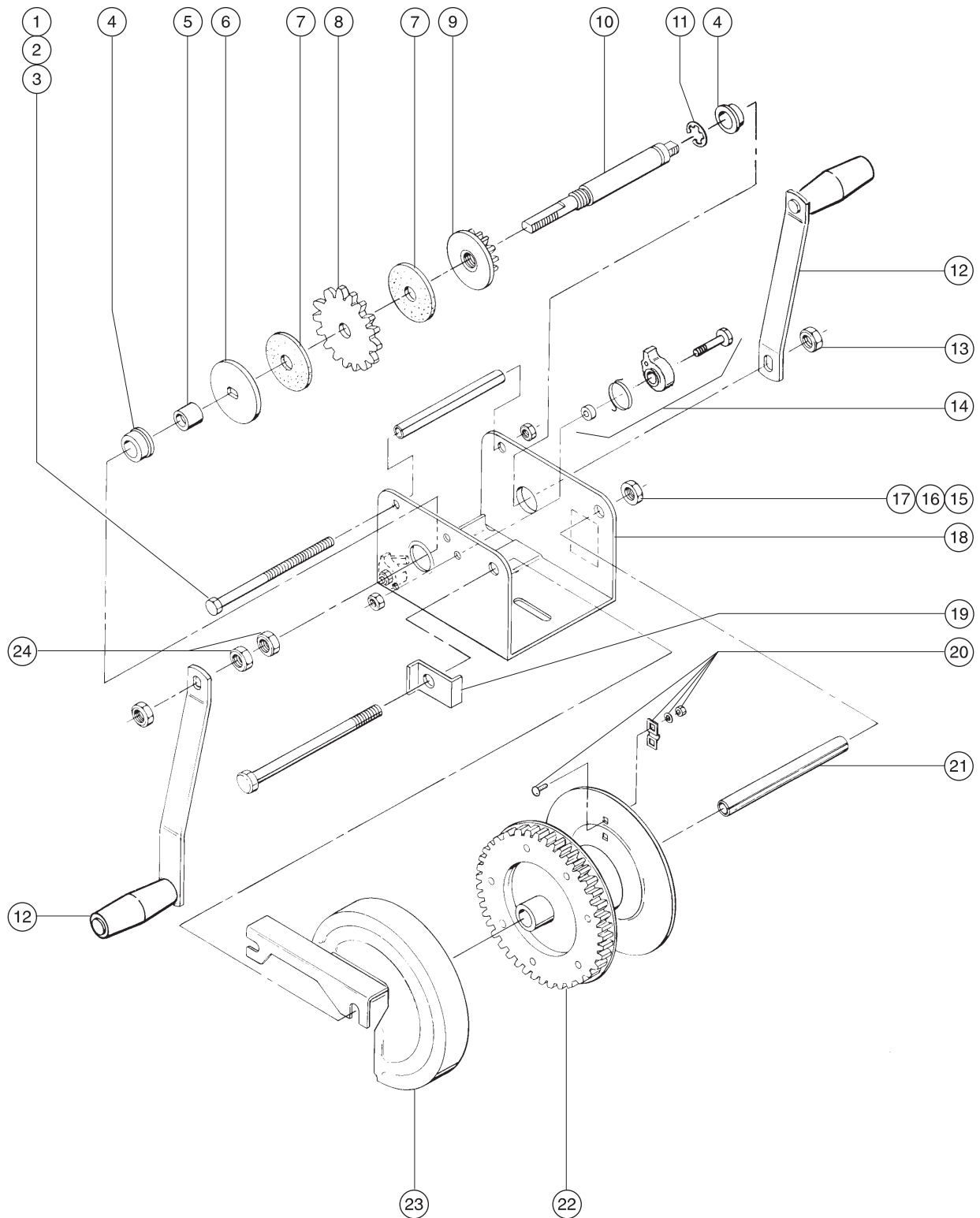

FIGURE 2-E

Index	Part No.	Description	Quantity This Figure
18	32892	Frame and Drum Support	1
19	31946	Drum Bolt Lock	1
20	6190	Cable Keeper Kit	1
21	6184	Spacer - Drum	1
22	Ref.	Drum Assembly	—
23	6770	Cover - Drum Gear	1
24	6034	Nut - Hex Jam, 1/2 -13	2

Notes



U.S.A.

18340 NE 76th Street
P.O. Box 69
Redmond, Washington
98073-0069



Europe

Brunel Drive
Newark
Nottinghamshire
NG24 2EG England